

parla*

Collection 2023

Parla Collection



We are a third generation furniture company that is continuing a legacy, that goes 113 years back.

We know why we shine bright;

We are talented.

We love craft.

We are tech oriented.

We work hard.

We move fast.

We are agile.

We are fully collaborative.

We thrive on problem solving.

We are a dedicated project partner.

We achieve the dreams of our project partners and we shine brighter together!



Hakan Öztunçman
Owner Director

Burak Öztunçman
Owner Director

A message from the Light Bearers of Parla

At Parla we are dedicated to chasing the light.

The blessed light of our grandfather who started this business as a loyal and respected furniture maker of The Ottoman Imperial Family.

The guiding light of our father, who taught us that we must take care of our customers and employees equally.

The sparkling light of our talented designers and hard-working factory workers.
The light that we see in the faces of our delighted customers.

At Parla what uplifts our day is not just creating beautiful pieces of furniture but creating exceptional, outstanding outcomes and constantly raising the bar when it comes to quality and care.

This vision has made Parla shine bright as a reliable, resilient, and globally respected company that designs, crafts and manufactures pieces that stand the test of time.

Every day, we are ready than ever, to shine brighter.

We are here to pour in light to your projects, and shine together with you.



Fusing Heritage, Crafts & Technology

Within our **15.000 sqm production facilities** consisting of workshops for wood, stainless steel and upholstery; we design and manufacture furniture using **hi-tech Italian machinery** alongside **experienced hand craftsman** who guide the process, and keep the heritage crafts element going.

Our **in house team of industrial designers & craftsmen** conceptualise, develop, design, and experiment with new ideas.

This brings about perfectly formed pieces of furniture that are fresh, cutting edge, technologically advanced and reflect Parla's heritage of traditional crafts in a contemporary manner.

We also welcome well known architects and designers to join us in creating new pieces, and run **'Product Creation Workshops'**.

In these workshops we marry the designer's expertise & innate talent with Parla's traditional & modern craft techniques, cutting edge technology and belief in **pushing boundaries**.

A Sustainable Future

We really do care...

About society, about the environment, about the economy.

We care about how we impact the environment. Nature is our mother!
We care about looking after her, and leaving the right kind of legacy for future generations.

We manufacture with sustainability in mind, constantly developing ways to be more in harmony with nature when using resources such as wood, steel, aluminium, textiles and plastics.

We care about people; we care about women, we care about young people. And, like many companies in this sector it is 'work in progress'; everyday we are realising more about what we can do and how we can implement changes.

Using the UN Sustainable Development Goals list as a yardstick, we have set up an internal team that prods, probes and pushes the whole company to do better. Of course not all 17 of the goals are related to our business, but the

Goals that we feel we are really working on are:

#3 Good Health and Well-Being

#4 Quality Education

#5 Gender Equality

#6 Clean Water and Sanitation

#7 Affordable and Clean Energy

#8 Decent Work & Economic Growth

#9 Industry, Innovation & Infrastructure

#10 Reduced Inequalities

#12 Responsible Consumption and Production

#13 Climate Action

#15 Life on Land

#17 Partnership for the Goals

Embedding these bigger picture Goals into our company culture is a journey in which we find ourselves inspired to then tackle specific areas on a micro level.





Our Practical Development Goals

By the end of 2023

- All adhesives and varnishes used will be water based.
- All our plastic packaging will be bio-degradable.
- 70% of our standard fabric options are manufactured in an environmentally conscious manner with Oeko-Tex, Greenguard and/or EU Eco Label certificates.
- 50% of our standard outdoor fabrics are recycled.

By 2025

- 80% of the products in our collection will use recycled fabrics.
- At least 20% of our Collection's product families will be crafted from sustainable, recycled and/or bio compostible materials.

By 2027

- We will have put a water recycling system in place for the whole factory and all drinking water will be supplied from these units.
- Our factory will reduce its water consumption by 80%.

By 2030

- 50% of our Collection's product families will be crafted from sustainable, recycled and/or bio compostible materials.
- Our production facilities will be using a renewable energy source.

Find out more about our sustainability goals at parladesign.com/sustainability

Our Design Ethos

FUSION

In each of our designs we fuse influences from our rich cultural heritage and the artisanal. We apply this to design; to form, to technique and to use of materials.

HARMONY

Every piece of furniture we design, craft and manufacture is a true reflection of our client's vision and sits in harmony with the environment it is being placed in.

RESPECT TO RESOURCES

In both design and manufacturing we set limits to how we apply our vast pool of resources and knowledge so that we are not exorbitant with the use of time, materials and labour.

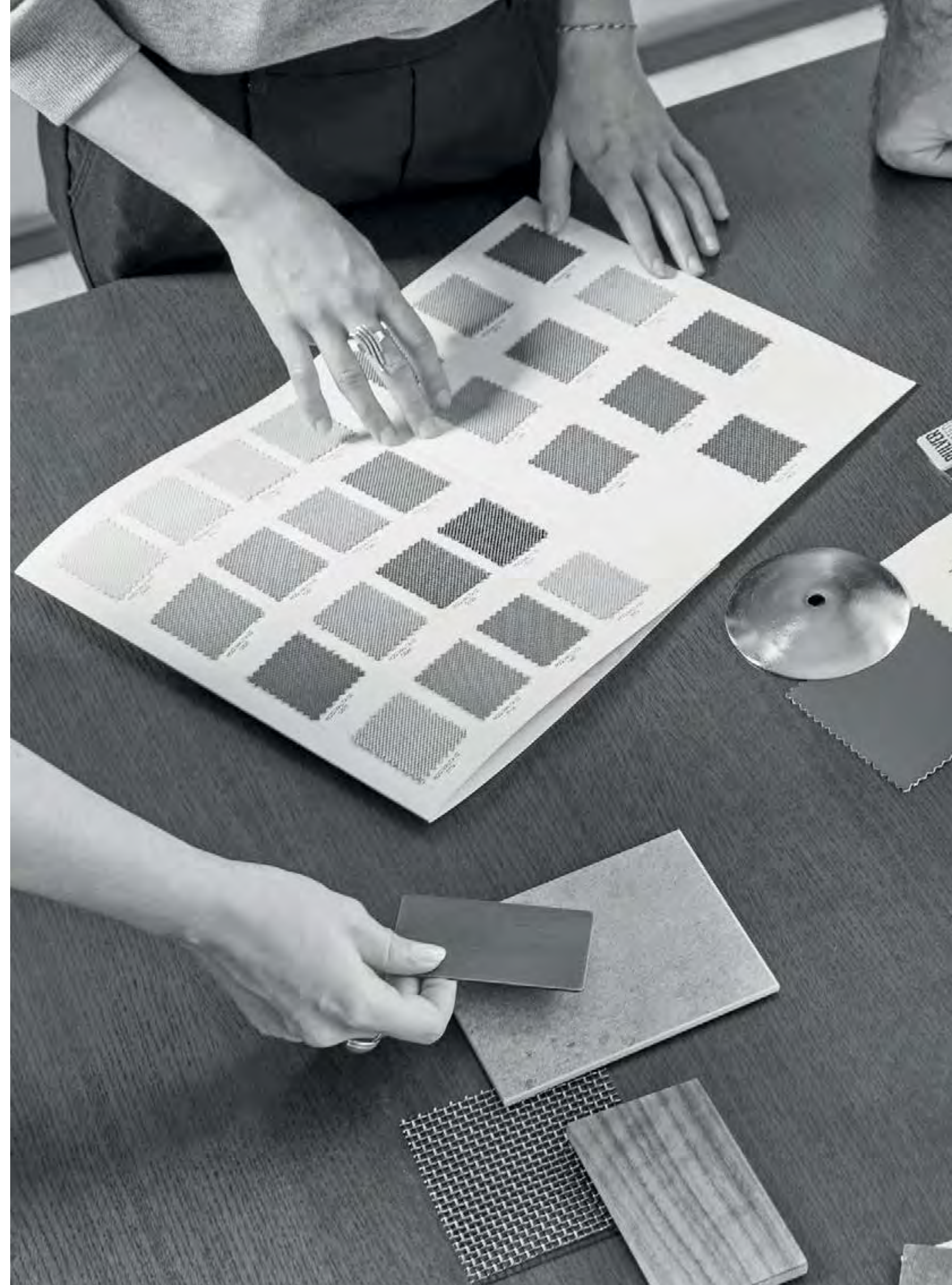

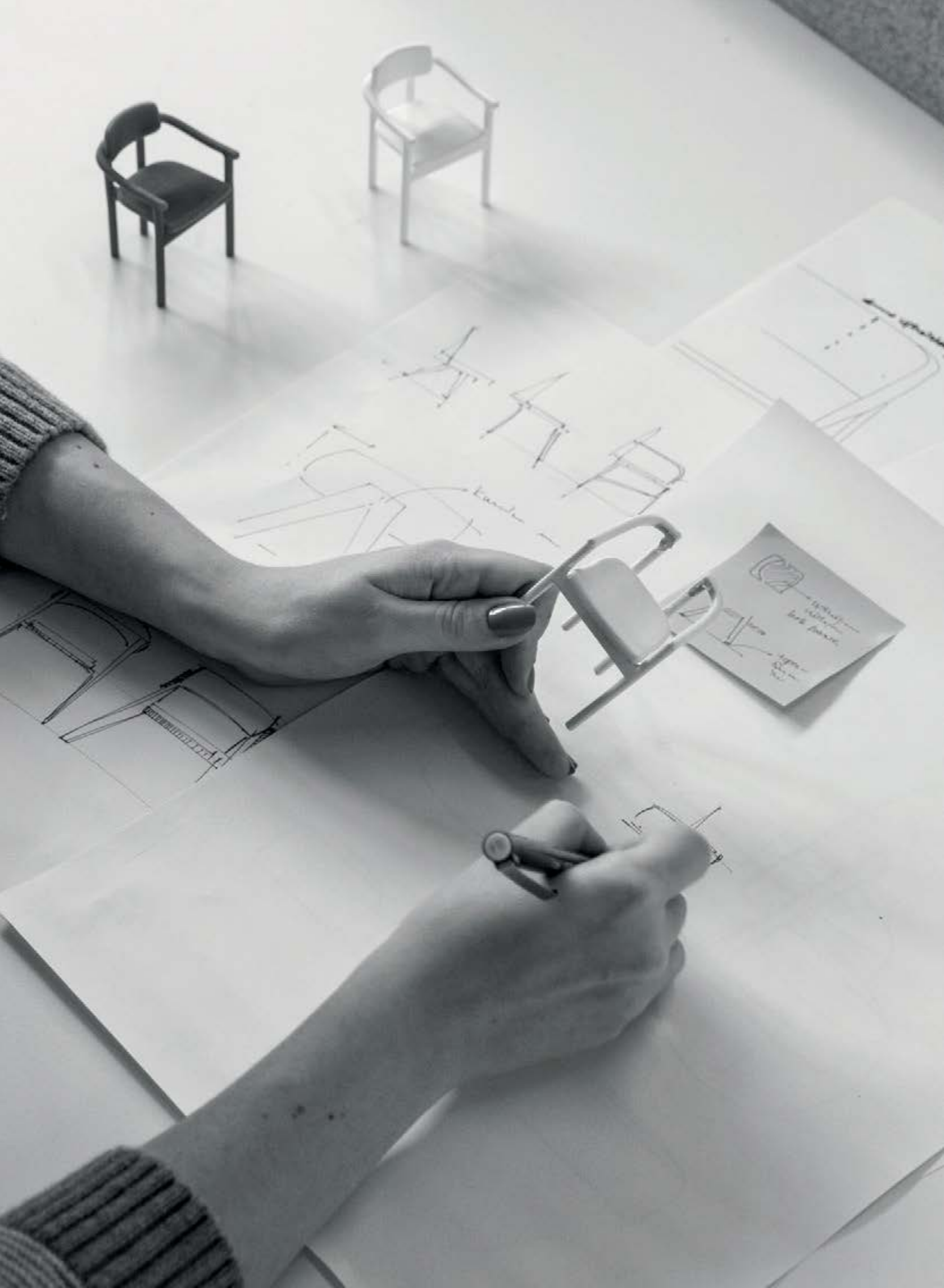

Designers





Betül İnci

Head of Parla Design Team, Betül started exploring ways of expression at a young age. Alongside her ultimate role model, her father, who was a teacher, sketching, designing and producing craft during her childhood years led to her building a professional career as a designer. She studied Industrial Product Design at Istanbul Technical University and Linneaus University in Sweden; following on from that she also added furniture design training at The Florence Institute of Design to her education.

From the Aegean region in Western Turkey to metropolitan Istanbul, Scandinavia to Mediterranean Italy, her multicultural education is very much reflected in her designs. She likes to use forms born from minimalism, add to that the inclusion of bold colours, she combines simplicity with extravagance in a poetic manner.

Betül has been working for Parla for 10 years and during this time she has participated in many projects spanning from New York to Dubai as Product Designer and Project Manager.

Betül's design Nigiri Chair has won the Good Design Award 2021 from The Chicago Athenaeum: Museum of Architecture and Design.



Aysel İlişik

Former Project Manager and Senior Designer of Parla, Aysel studied Industrial Design at Anadolu University and started her career as a product designer in Istanbul.

As a highly experienced furniture designer and business development enthusiast; Aysel is focused on building and maintaining Parla's exceptional customer relationships within the A&D community.

Specialized in Hospitality interiors with a deep understanding of high-end and bespoke furniture; she is currently working as the Head of Designer Relations.



Deniz Albayrak

Born in Bulgaria, Deniz studied Industrial Design at Anadolu University and moved to Istanbul after his graduation.

Starting his career as a product designer in Parla, he is currently one of the co-founders of Parla Studio, while continuing his development in management roles in the company.

His Professional development has taken him from being a Project Manager to a Pre-Contract Manager to currently working for Parla as a Senior Projects Manager, living and working from Parla's London Office.



Erden Dereli

After graduating from Anadolu University; Erden completed his design internship at d'Arc Studio Roma. Moving forward to his professional career in Parla; he worked 4 years as an Industrial Designer and 3 years as a Production Planning Manager, where he experienced various projects of mid to large scale all over the world for contract products.

Being one of the founders of Parla Studio, Erden currently continues his work specialising on production processes. His designs are mainly focused on materials, functionalities, manufacturability and R&D industry.



Berrak İlkcan Şener

Born in Fethiye, studied in Eskisehir and based as a designer in Istanbul, Berrak was awarded by BigSee for her design of the Rimo Armchair in 2022. Berrak completed her Bachelor's degree in Industrial Design at Anadolu University. During her education, she participated in a student exchange program at HAWK Hochschule University, Hildesheim, Germany.

Moving forward she based her designs on these influences, combining them with her unique ideas. Aiming for timeless, clean and functional product designs.

Berrak creates durable and user friendly products which are also timeless in their look.



Seda Yetkiner

Seda studied Industrial Design at Anadolu University and made a quick start to her career at the same time at Yakamoz Glass designing niche objects and installations. During her years there, she found the opportunity to practise and become a master at hot glass production, which then became her passion – creating glass objects is now her most favoured hobby. She joined Parla Design Studio in 2019, widening her experience with new materials.

Her approach to design is reflected in furniture through bold shapes, that are warm, familiar, grounded and functional whilst embellished with elegant details.



Enis Altinkaynak

Enis was always fond of exploring his imagination via his drawings.

After graduating from Anadolu University, he proceeded on to a master's degree at Marmara University where he continues his research on the effects of modern technologies within the area of product design, while lecturing upcoming Industrial Designers at Beykent University. While enjoying every design ideology, Enis actually prefers to follow a totalitarian approach when it comes to design.

Always trying to reach excellence, he is fond of learning about materials and production processes in order to master them.



Yasemin Derici Çeri

During her studies of Industrial Design in Izmir; she and 4 of her friends set up a brand that created handmade concrete trays & objects. Following their passion for design and identity, they took part in the Milan Design Market, as part of Milan Design Week, and launched their product line there.

Focusing on product design, photoshoot styling, trend research, social media managing, visual, creative, and digital media creation for marketing, Yasemin continues her career as an Art Director.

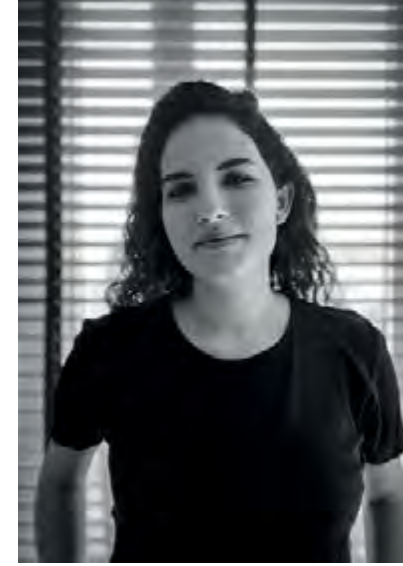

Burcu Özdamar

After graduating from Middle East Technical University, Department of Industrial Design, she started working at Parla.

Working in cooperation with experienced craftsmen in the workshop, she learned the nature of the materials closely. The combination of different textures, geometric games and East-West identity synthesis can be easily experienced in her products. The designer, who cares about understanding the needs of both the user and space, stands out with her customizable products.

Burcu is currently working as a product manager and continues her design projects personally.



Umut Kargınoğlu

Born in Gaziantep, Umut studied Industrial Product Design at Istanbul Technical University and settled in Istanbul to base his design career in the city. During his internships, he gained experience on ideation and production methods for office, restaurant and urban furniture design.

Highly skilled in Product Design, Model Making, Branding & Identity, Concept Generation accompanied with a strong engineering experience for professional production techniques, Umut is currently working as a Product Design and Development Specialist.



Buket Hoşcan Bazman

Buket Hoşcan Bazman was born in Izmir, Turkey, in 1989. Graduated from the Işık University and after few years of working in the industry, she founded her own design brand under the name "Marbleous" in 2015, which produces marble detailed furniture and objects. In 2018, Buket set up her own design studio.

Currently, she is working on contemporary collectible pieces.

Buket focuses on traditional craftsmanship with natural materials. Each piece is made by craftsmen based in Turkey.



David Fox

David Fox Design, is a multi-award winning industrial and product design studio with awards from Red Dot, Good Design Award to FX product designer of the Year in 2009.

Their spectrum of product designs range from furniture, to bathroom basins, faucets, cabinet hardware, fabric and carpet design.

Their international client base covers: Belgium, Turkey, UK, Italy, Czech republic, Canada, Poland & Spain.



Esin Sözer Kalender

Arketipo Design was founded by Murad Denizaltı , Müge Hansoy Kınacı and Esin Sözer Kalender in 1994. For the past 27 years, they have worked on various Hotel, Spa, Shopping Center, Office and Residential projects; achieving successful results in each.

They have achieved over 80 projects in their country of headquarters, Turkey and have also achieved 100 completed projects in various countries such as Dubai, Germany, Russia, Libya, Kazakhstan and Ukraine.



Klan Studio

Founded by Eşref Akın Oral and Işık Görgün Oral, Klan Studio is a design studio working primarily on furniture, yacht and machinery design sectors.

They like to define themselves as “modernists” prioritizing the efficiency of casuality and dominance of clever design.

What they want to underline, is always superiority of consistency. Naturally, making sure they always deliver the “right design” for every brief they come across.



Kilit Taşı Design Studio

Kilit Taşı is a design studio based in Istanbul which provides industrial design, design management, strategic design consultancy services to companies from different sectors. Co-founder Kunter Sekercioglu values cultural traits, craftsmanship, history and the details of daily life as points of inspiration for his designs.

He believes that quality in design is defined by distinction, innovation, enjoyment, practicality and affordability. In order to achieve this, he chooses to participate actively in every stage of the process, starting from the initial sketches all the way to the launch of the production.





Chairs



Fau A Chair



Designer Kilit Taşı

Frame: Solid ash structure
Seat & Back: Upholstered seat
Finish: Available in multiple stain colours

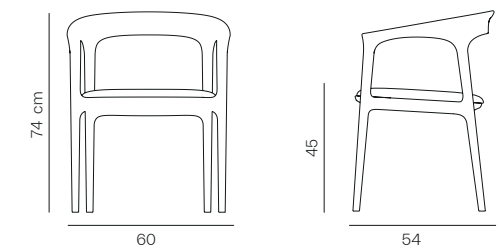

Dimensions

W 60 D 54 H 74 Seat height: 46 cm



Good Design® Award winner from
The Chicago Athenaeum: Museum of
Architecture and Design

Nigiri Chair



Designer Betül İnci

Frame: Solid ash structure
Seat & Back: Upholstered seat and back
Finish: Available in multiple stain colours

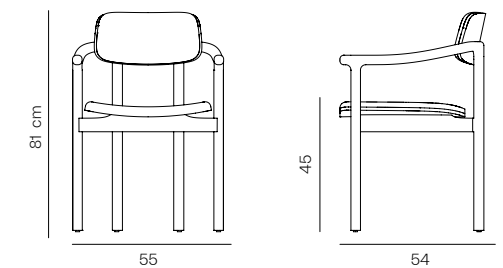

Dimensions

W 55 D 54 H 81 Seat height: 45 cm



Monochrome Galataport - Istanbul, Turkey

Gala V Chair



Designer Burcu Özdamar

Frame: Ash veneer Plywood back and solid ash legs
Seat & Back: Upholstered seat and back
Finish: Available in multiple stain colours

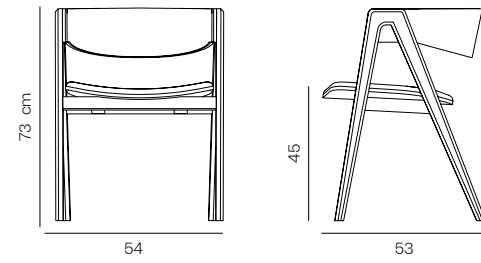

Dimensions

W 54 D 53 H 73 Seat height: 45 cm

Venus A Chair



Designer Betül İnci

Frame: Solid beech structure
Seat & Back: Upholstered seat and back
Finish: Available in multiple stain colours

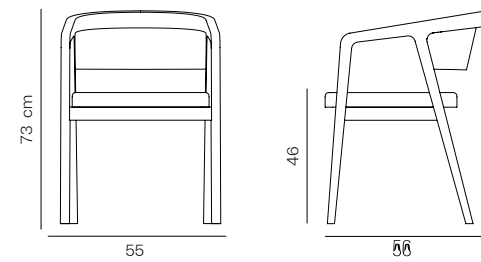

Dimensions

W 55 D 56 H 73 Seat height: 46 cm

Venus Chair



Designer Betül İnci

Frame: Solid beech structure
Seat & Back: Upholstered seat and back
Finish: Available in multiple stain colours

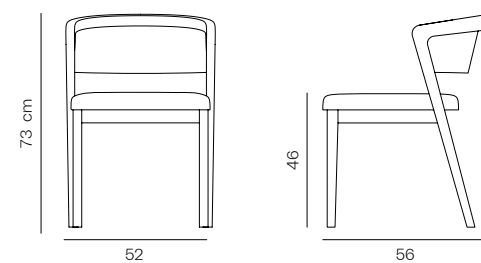

Dimensions

W 52 D 56 H 73 Seat height: 46 cm







Holiday Inn Heathrow - London, UK

Arven Chair



Designer Burcu Özdamar

Frame: Plywood back and solid beech legs, metal, brass or stainless steel arms (with powder coated metal and coloured steel options)

Seat & Back: Upholstered seat and back

Finish: Available in multiple stain colours, arms available in Antique Brass, RAL or steel colours

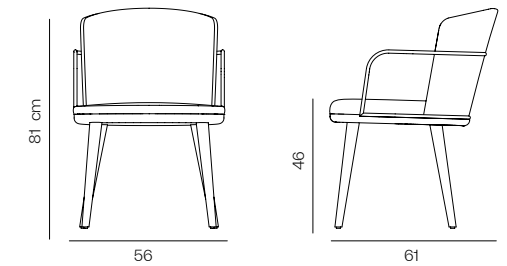

Dimensions

W 56 D 61 H 81 Seat height: 46 cm

Arven L Chair



Designer Burcu Özdamar

Frame: Plywood back and solid beech legs

Seat & Back: Upholstered seat and back

Finish: Available in multiple stain colours

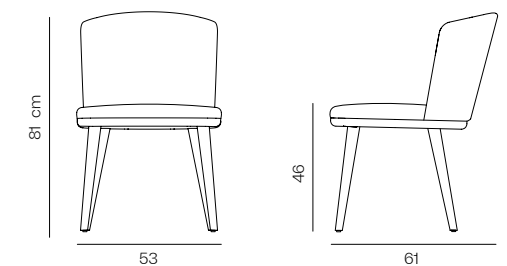

Dimensions

W 53 D 61 H 81 Seat height: 46 cm

Oyster Chair



Designer Enis Altinkaynak

Frame: Plywood back and solid ash legs
Seat & Back: Upholstered seat and back
Finish: Available in multiple stain colours

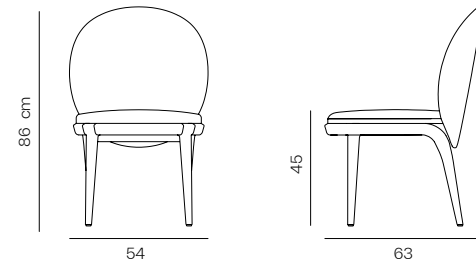

Dimensions

W 54 D 63 H 86 Seat height: 45 cm

Oyster W Chair



Designer Enis Altinkaynak

Frame: Plywood back and metal or stainless steel legs
(with powder coated metal and coloured steel options)
Seat & Back: Upholstered seat and back
Finish: Available in RAL or steel colours

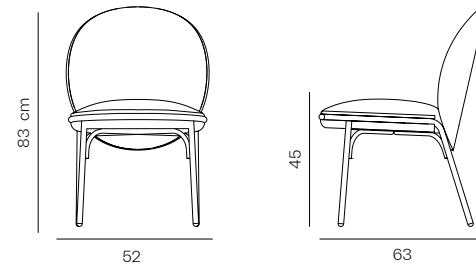

Dimensions

W 52 D 63 H 83 Seat height: 45 cm

Oyster WA Chair



Designer Enis Altinkaynak

Frame: Plywood back and metal or stainless steel legs
(with powder coated metal and coloured steel options)
Seat & Back: Upholstered seat and back
Finish: Available in RAL or steel colours

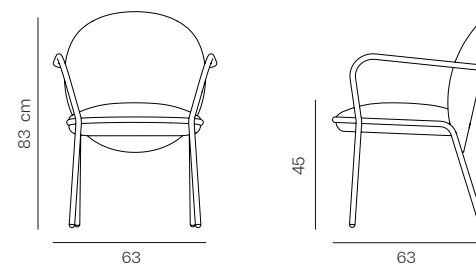

Dimensions

W 63 D 63 H 83 Seat height: 45 cm





Meru Chair



Designer Burcu Özdamar

Frame: Powder coated metal structure with moulded polyurethane back
 Seat & Back: Upholstered seat and back
 Finish: Available in RAL colours

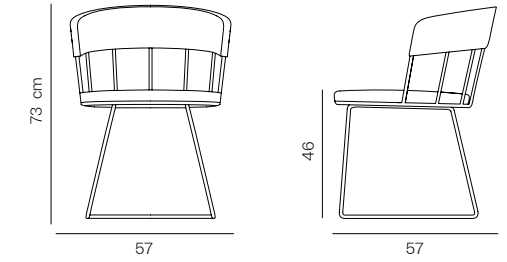

Dimensions
 W 57 D 57 H 73 Seat height: 46 cm

Meru L Chair



Designer Burcu Özdamar

Frame: Powder coated metal structure with moulded polyurethane back and solid beech structure
 Seat & Back: Upholstered seat and back
 Finish: Available in multiple stain colours, back available in RAL colours

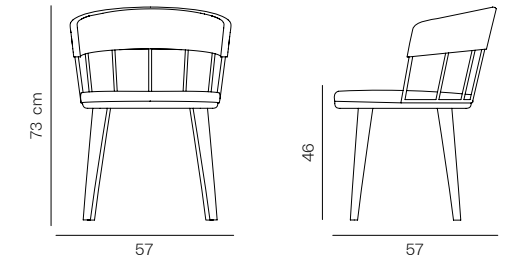

Dimensions
 W 57 D 57 H 73 Seat height: 46 cm

Kybele WF Chair



Designer Erden Dereli

Frame: Solid ash structure
 Seat & Back: Upholstered seat, back and arms
 Finish: Available in multiple stain colours

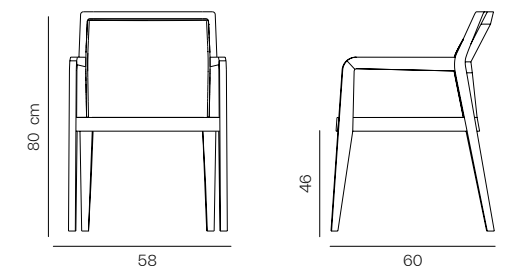

Dimensions
 W 58 D 60 H 80 Seat height: 46 cm

Chia Chair



Designer Betül İnci

Frame: Plywood back and metal or stainless steel legs
(with powder coated metal and coloured steel options)
Seat & Back: Upholstered seat and back
Finish: Available in RAL or steel colours

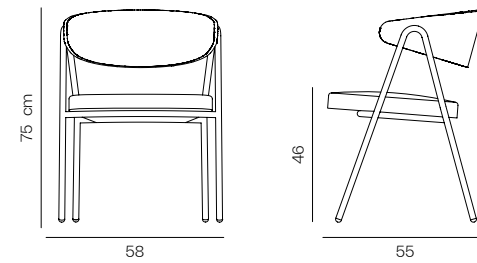

Dimensions

W 58 D 55 H 75 Seat height: 46 cm

Rimo Chair



Designer Berrak İlkcan Şener

Frame: Plywood back and metal or stainless steel legs
(with powder coated metal and coloured steel options)
Seat & Back: Upholstered seat and back
Finish: Available in RAL or steel colours

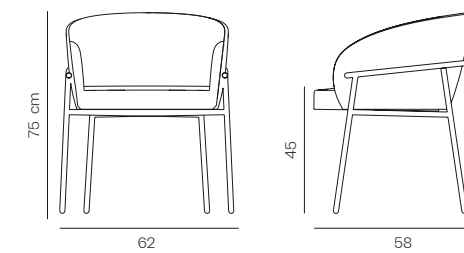

Dimensions

W 62 D 58 H 75 Seat height: 45 cm





Pınar Hotel - Balıkesir, Turkey

Olive Chair



Designer Betül İnci

Frame: Moulded polyurethane back and solid beech structure
Seat & Back: Upholstered seat and back
Finish: Available in multiple stain colours

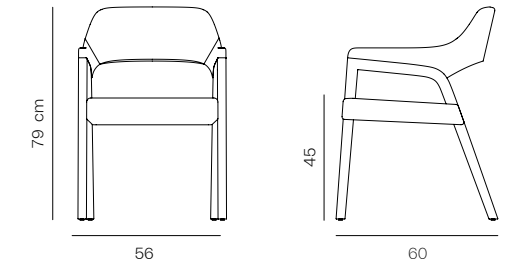

Dimensions

W 56 D 60 H 79 Seat height: 45 cm

Atlas A Chair



Designer Betül İnci

Frame: Plywood back and solid beech legs
Seat & Back: Upholstered seat and back
Finish: Available in multiple stain colours

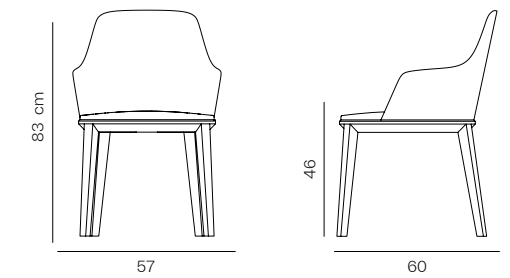

Dimensions

W 57 D 60 H 83 Seat height: 46 cm

Atlas Chair



Designer Betül İnci

Frame: Plywood back and solid beech legs
Seat & Back: Upholstered seat and back
Finish: Available in multiple stain colours

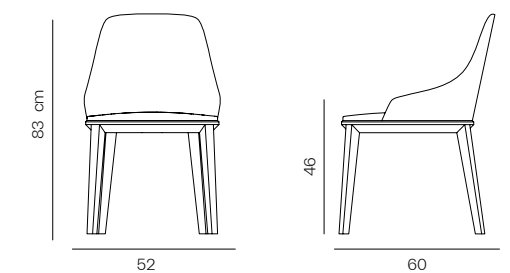

Dimensions

W 52 D 60 H 83 Seat height: 46 cm



Mate XL Chair



Designer Aysel İlişik

Frame: Beech plywood back and seat, solid beech structure
Seat & Back: Upholstered seat and back
Finish: Available in multiple stain colours

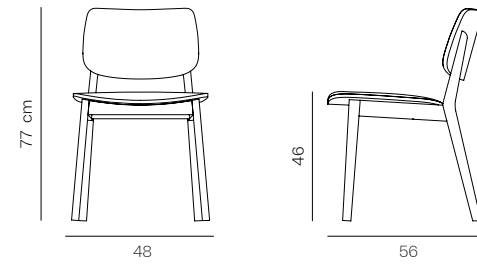

Dimensions

W 48 D 56 H 77 Seat height: 46 cm

Mate XL V Chair



Designer Aysel İlişik

Frame: Beech plywood back and seat, solid beech structure
Finish: Available in multiple stain colours

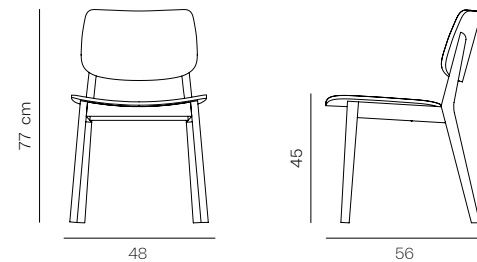

Dimensions

W 48 D 56 H 77 Seat height: 45 cm





Liman Restaurant - Istanbul, Turkey

Ren Chair



Designer Betül İnci

Frame: Plywood back with solid beech legs
Seat & Back: Upholstered seat and back
Finish: Available in multiple stain colours

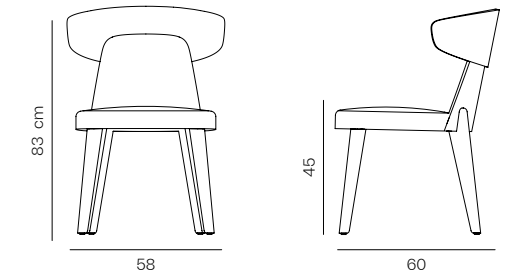

Dimensions

W 58 D 60 H 83 Seat height: 45 cm

Ren P Chair



Designer Betül İnci

Frame: Plywood back and solid beech legs
Seat & Back: Upholstered seat and back
Finish: Available in multiple stain colours

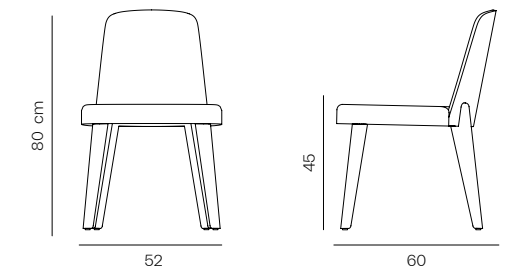

Dimensions

W 52 D 60 H 80 Seat height: 45 cm

Luna A Chair



Designer Betül İnci

Frame: Solid beech structure
Seat: Upholstered seat
Finish: Available in multiple stain colours

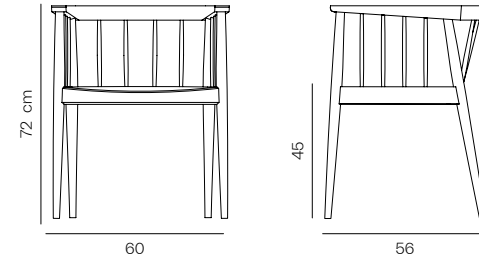

Dimensions
W 60 D 56 H 72 Seat height: 45 cm

Remus Chair



Designer David Fox

Frame: Moulded polyurethane body with solid beech legs
Seat & Back: Upholstered seat and back
Finish: Available in multiple stain colours

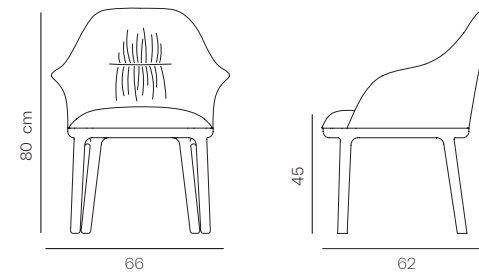

Dimensions
W 66 D 62 H 80 Seat height: 45 cm

Remus S Chair



Designer David Fox

Frame: Moulded polyurethane body, solid beech legs
Seat & Back: Upholstered seat and back
Finish: Available in multiple stain colours

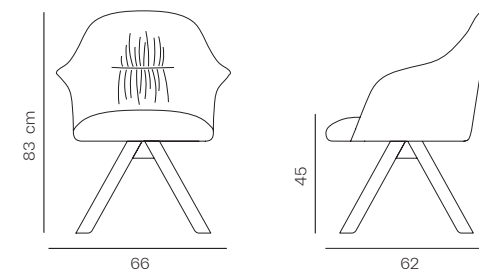

Dimensions
W 66 D 62 H 83 Seat height: 45 cm





Meatco Steakhouse - Istanbul, Turkey

Sabien Chair



Designer David Fox

Frame: Plywood back and solid beech legs
 Seat & Back: Upholstered quilted seat and back
 Finish: Available in multiple stain colours

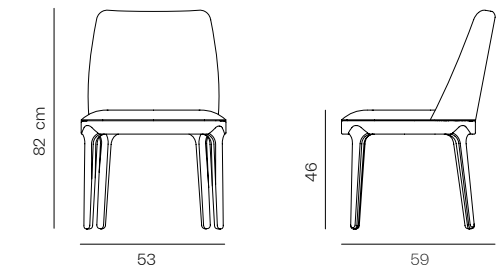

Dimensions

W 53 D 59 H 82 Seat height: 46 cm

Sabien A Chair



Designer David Fox

Frame: Plywood back and solid beech legs
 Seat & Back: Upholstered quilted seat and back
 Finish: Available in multiple stain colours

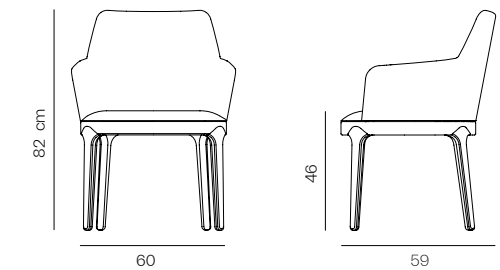

Dimensions

W 60 D 59 H 82 Seat height: 46 cm

Mod Chair



Designer Betül İnci

Frame: Moulded polyurethane body with solid beech legs
 Seat & Back: Upholstered seat and back
 Finish: Available in multiple stain colours

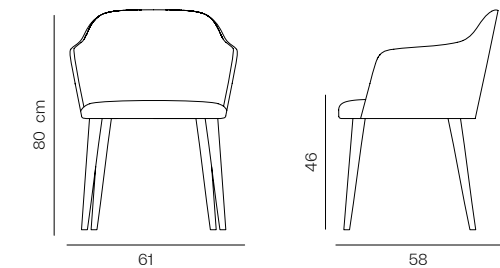

Dimensions

W 61 D 58 H 80 Seat height: 46 cm

Stella Chair



Designer Betül İnci

Frame: Plywood back and solid beech legs
Seat & Back: Upholstered seat and back
Finish: Available in multiple stain colours

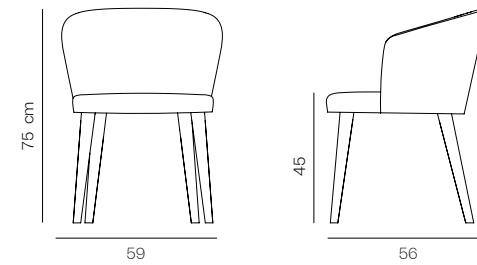

Dimensions

W 59 D 56 H 75 Seat height: 45 cm

Stella V Chair



Designer Betül İnci

Frame: Oak veneer plywood back and solid beech legs
Seat & Back: Upholstered seat and inner back
Finish: Available in multiple stain colours

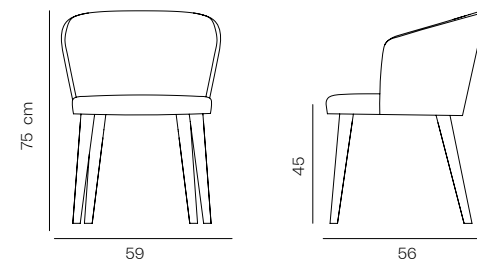

Dimensions

W 59 D 56 H 75 Seat height: 45 cm

Stella W Chair



Designer Betül İnci

Frame: Plywood back and powder coated metal leg
Seat & Back: Upholstered seat and back
Finish: Available in RAL colours

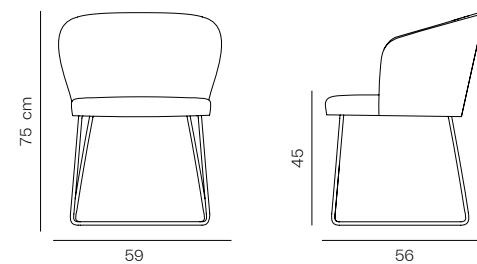

Dimensions

W 59 D 56 H 75 Seat height: 45 cm



Haugen - London, UK





Mod W Chair



Designer Betül İnci

Frame: Moulded polyurethane body with powder coated metal leg
Seat & Back: Upholstered seat and back
Finish: Available in RAL colours

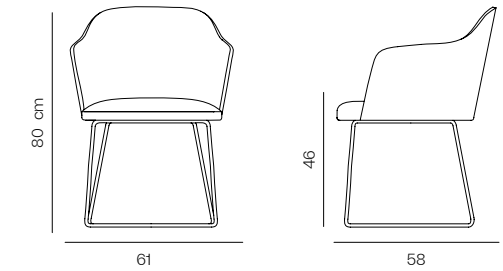

Dimensions

W 61 D 58 H 80 Seat height: 46 cm

Mod S Chair



Designer Betül İnci

Frame: Moulded polyurethane body with die-cast aluminium swivel base
Seat & Back: Upholstered seat and back
Finish: Available polished chrome and black

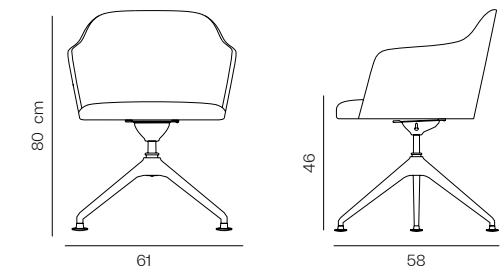

Dimensions

W 61 D 58 H 80 Seat height: 46 cm

Mod RS Chair



Designer Betül İnci

Frame: Moulded polyurethane body with die-cast aluminium swivel base with castors
Seat & Back: Upholstered seat and back
Finish: Available polished chrome and black

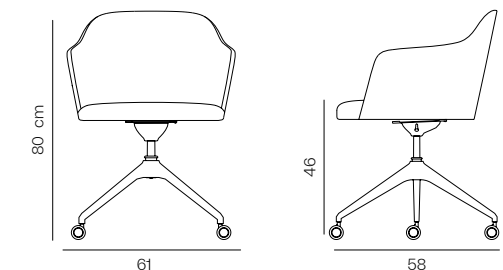

Dimensions

W 61 D 58 H 80 Seat height: 46 cm



Armchairs



Painting by Ahmet Çerkez

Hug Armchair



Designer Betül İnci

Frame: Plywood and solid beech structure, oak wood base
Seat & Back: Upholstered seat and back
Finish: Available in multiple stain colours

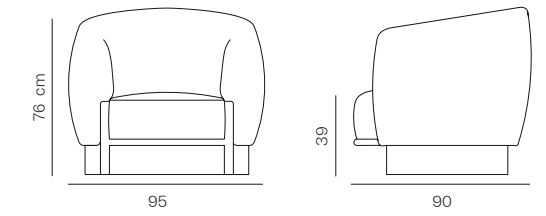

Dimensions

W 95 D 90 H 76 Seat height: 39 cm

Moose Armchair



Designer Deniz Albayrak

Frame: Solid ash back structure, ash veneer base
Seat & Back: Upholstered seat
Finish: Available in multiple stain colours

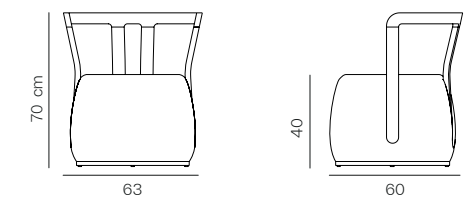

Dimensions

W 63 D 60 H 70 Seat height: 40 cm



Rimo Armchair



Designer Berrak İlkcan Şener

Frame: Moulded polyurethane body and metal or stainless steel legs (with powder coated metal and coloured steel options)
Seat & Back: Upholstered seat and back
Finish: Available in RAL or steel colours

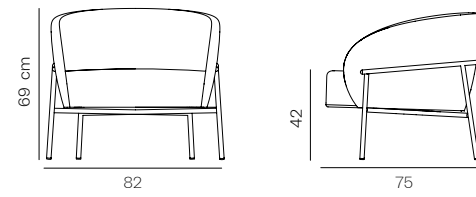

Dimensions

W 82 D 75 H 69 Seat height: 42 cm

Oyster W Armchair



Designer Enis Altinkaynak

Frame: Plywood back and metal or stainless steel legs (with powder coated metal and coloured steel options)
Seat & Back: Upholstered seat and back
Finish: Available in RAL or steel colours

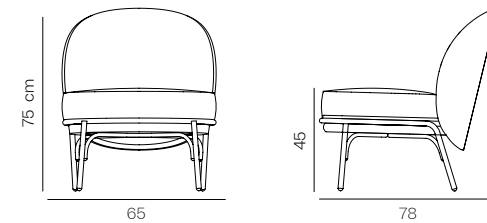

Dimensions

W 65 D 78 H 75 Seat height: 45 cm





Xaylon Armchair



Designer David Fox

Frame: Moulded polyurethane body and solid beech legs
 Seat & Back: Upholstered seat and back
 Finish: Available in multiple stain colours

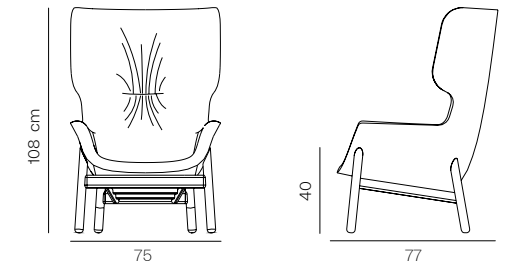

Dimensions

W 75 D 77 H 108 Seat height: 40 cm

Xaylon W Armchair



Designer David Fox

Frame: Moulded polyurethane body and metal or stainless steel legs (with powder coated and coloured steel options)
 Seat & Back: Upholstered seat and back
 Finish: Available in RAL or steel colours

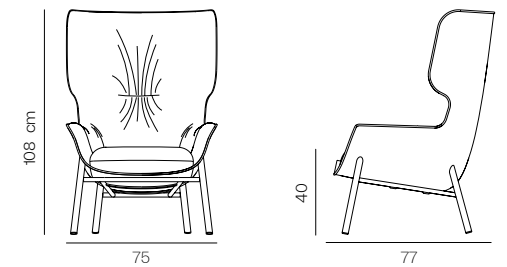

Dimensions

W 75 D 77 H 108 Seat height: 40 cm

Eve Wing Back Armchair



Designer Erden Dereli

Frame: Plywood and solid beech structure and solid beech legs
 Seat & Back: Upholstered seat and back
 Finish: Available in multiple stain colours

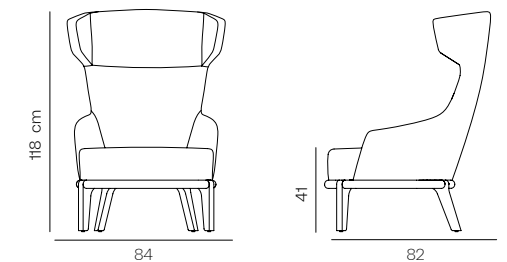

Dimensions

W 84 D 82 H 118 Seat height: 41 cm

Remus Armchair



Designer David Fox

Frame: Moulded polyurethane body, solid beech legs
Seat & Back: Upholstered seat and back
Finish: Available in multiple stain colours

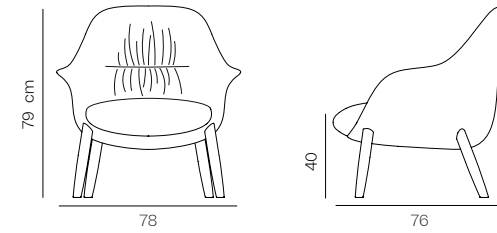

Dimensions

W 78 D 76 H 79 Seat height: 40 cm

Atlas Armchair



Designer Betül İnci

Frame: Plywood and solid beech structure, solid beech legs
Seat & Back: Upholstered seat and back
Finish: Available in multiple stain colours

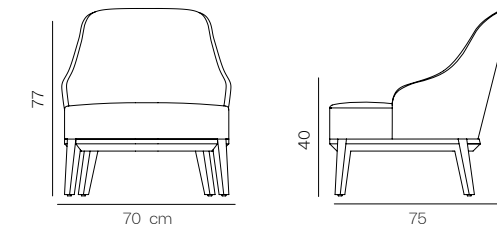

Dimensions

W 70 D 75 H 77 Seat height: 42 cm

Atlas V Armchair



Designer Betül İnci

Frame: Plywood and solid beech structure, solid beech legs
Seat & Back: Upholstered seat and back
Finish: Available in multiple stain colours

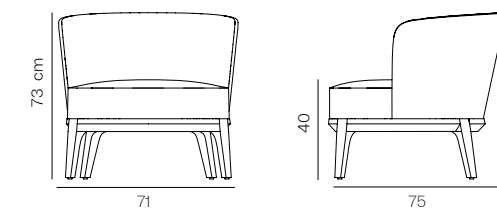

Dimensions

W 71 D 75 H 73 Seat height: 40 cm



Ruya Restaurant - London, UK

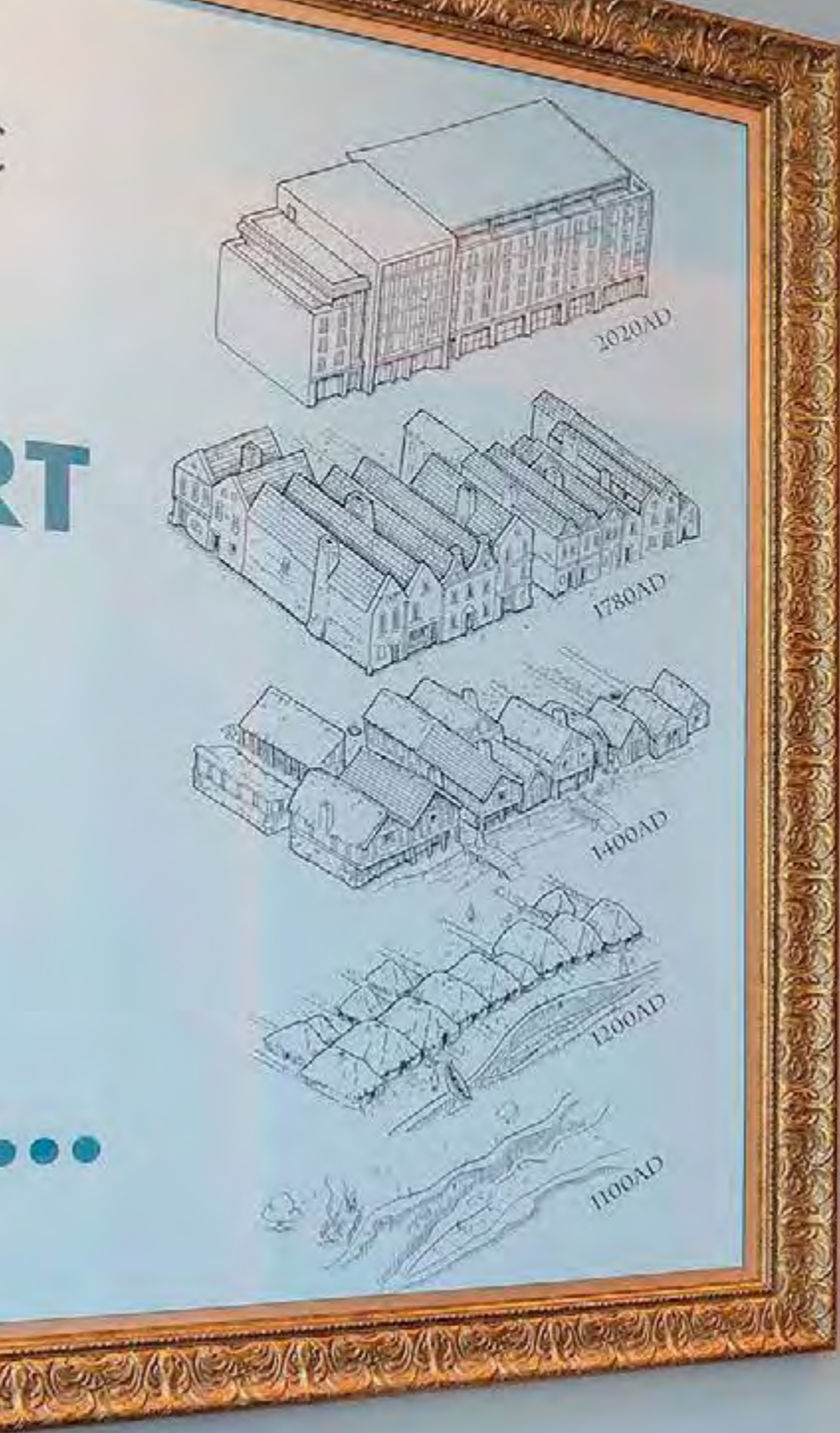

10th CENTURY



11th - 12th CENTURY



10th - 11th CENTURY



10th - 13th CENTURY



10th - 12th CENTURY



12th CENTURY



12th CENTURY



12th - 13th CENTURY



12th CENTURY



12th CENTURY



12th CENTURY



12th CENTURY



12th CENTURY



12th CENTURY



12th CENTURY



12th CENTURY





Orelle - Birmingham, UK

Padova Armchair



Designer Betül İnci

Frame: Plywood structure, oak veneer plywood back and base (with 360° swivel base option)
 Seat & Back: Upholstered seat and inner back
 Finish: Available in multiple stain colours

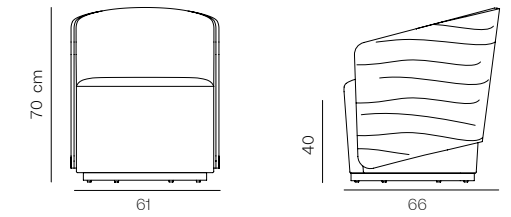

Dimensions
W 61 D 66 H 70 Seat height: 40 cm

Padova U Armchair



Designer Betül İnci

Frame: Moulded polyurethane back and plywood structure with natural oak veneer base (with 360° swivel base option)
 Seat & Back: Upholstered seat and back
 Finish: Available in multiple stain colors

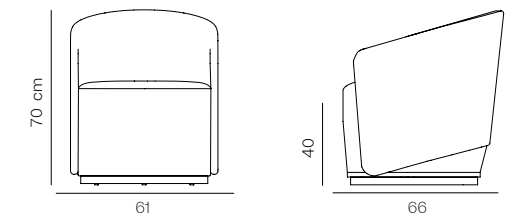

Dimensions
W 61 D 66 H 70 Seat height: 40 cm

Bloom Club Armchair



Designer Betül İnci

Frame: Plywood and solid beech structure (with 360° swivel base option)
 Seat & Back: Upholstered seat and back cushions

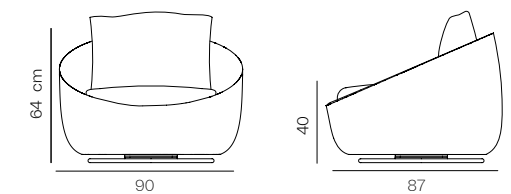

Dimensions
W 90 D 87 H 64 Seat height: 40 cm

Net Armchair



Designer Betül İnci

Frame: Plywood and solid beech structure
 Seat & Back: Upholstered seat and inner back, woven banana fiber back
 Finish: Available in multiple stain colours

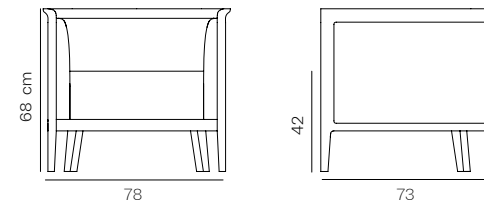

Dimensions

W 78 D 73 H 68 Seat height: 42 cm

Net WF Armchair



Designer Betül İnci

Frame: Plywood and solid beech structure
 Seat & Back: Upholstered seat, inner and outer back
 Finish: Available in multiple stain colours

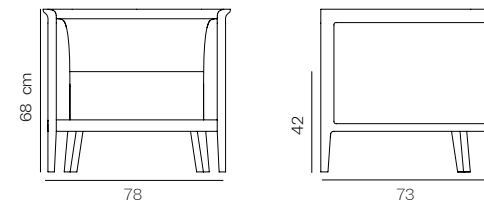

Dimensions

W 78 D 73 H 68 Seat height: 42 cm

Goba Armchair



Designer Esin Sözer Kalender

Frame: Solid beech structure
 Seat & Back: Upholstered seat and back cushions
 Finish: Available in multiple stain colours

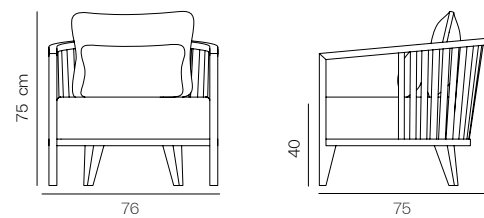

Dimensions

W 76 D 75 H 75 Seat height: 40 cm





Roberto's Restaurant Dubai - Dubai, UAE

Milla Armchair



Designer Parla Studio

Frame: Plywood and solid beech structure, solid beech legs
 Seat & Back: Upholstered seat and back
 Finish: Available in multiple stain colours

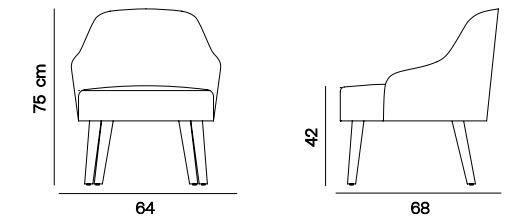

Dimensions
W 64 D 68 H 75 Seat height: 42 cm

Luce Armchair



Designer Betül İnci

Frame: Plywood and solid beech structure, powder coated metal legs
 Seat & Back: Upholstered seat and back
 Finish: Available in RAL colours

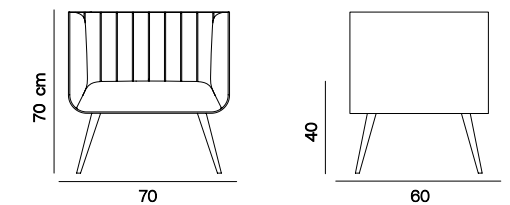

Dimensions
W 70 D 60 H 70 Seat height: 40 cm

Estival Armchair



Designer Parla Studio

Frame: Plywood and solid beech structure, powder coated metal base
 Seat & Back: Upholstered seat, back and cushions
 Finish: Available in RAL colours

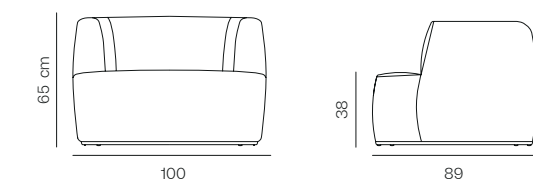

Dimensions
W 100 D 89 H 65 Seat height: 38 cm

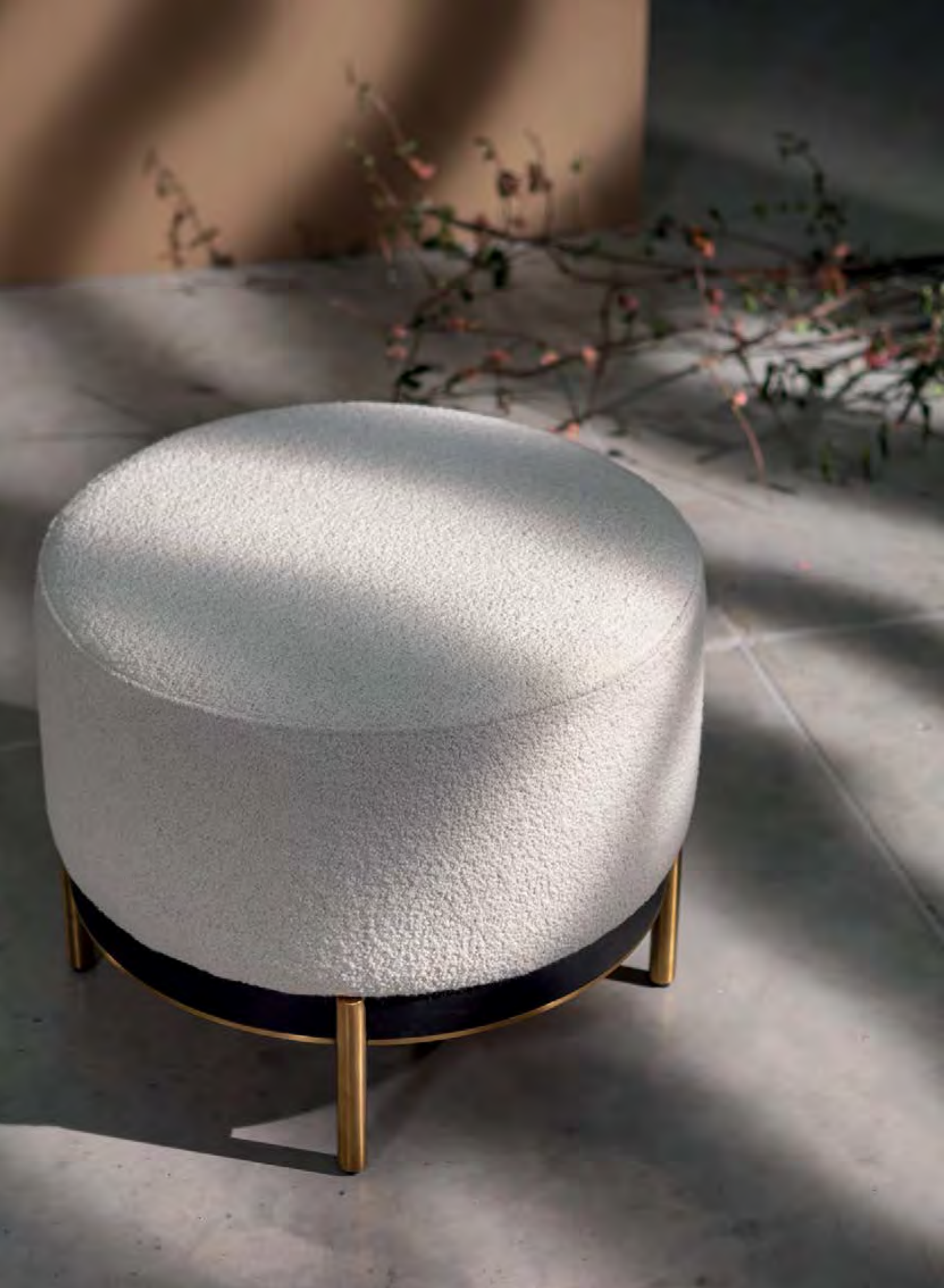

Stools & Poufs

Remus Pouf

Designer David Fox

Frame: Plywood structure and solid beech legs
 Seat: Upholstered seat
 Finish: Available in multiple stain colours

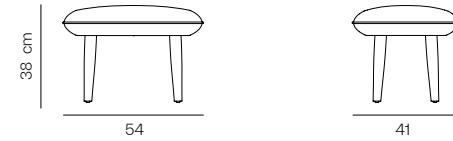

Dimensions
W 54 D 41 H 38 cm

Luce Stool

Designer Betül İnci

Frame: Beech veneer plywood and powder coated metal legs
 Seat: Upholstered seat
 Finish: Available in RAL colours and seat base available in multiple stain colours

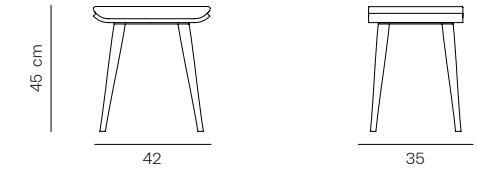

Dimensions
W 42 D 35 H 45 cm

Atlas Pouf

Designer Betül İnci

Frame: Plywood structure, solid beech legs
 Seat: Upholstered seat
 Finish: Available in multiple stain colours

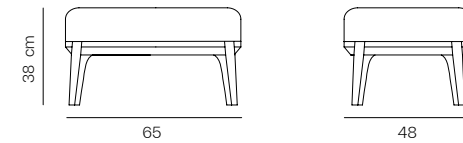

Dimensions
W 65 D 48 H 38 cm

Luce Foot Stool

Designer Betül İnci

Frame: Beech veneer plywood and powder coated metal legs
 Seat: Upholstered seat
 Finish: Available in RAL colours and seat base available in multiple stain colours

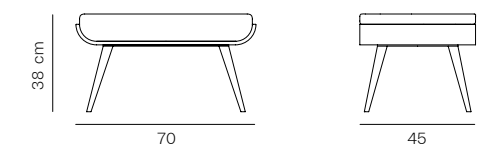

Dimensions
W 70 D 45 H 38 cm

London Pouf

Designer Burcu Özdamar

Frame: Plywood and solid beech structure, wood veneer base and metal or stainless steel legs (with powder coated metal and coloured steel options)
 Seat: Upholstered seat
 Finish: Base available in natural walnut or oak veneer with multiple stain colours, legs available in RAL or steel colours

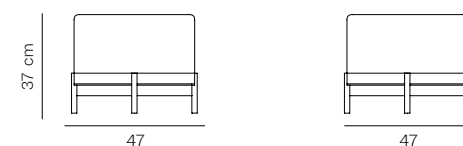

Dimensions
W 47 D 47 H 37 cm

Rocks Pouf

Designer Deniz Albayrak

Frame: Plywood structure
 Seat: Upholstered seat

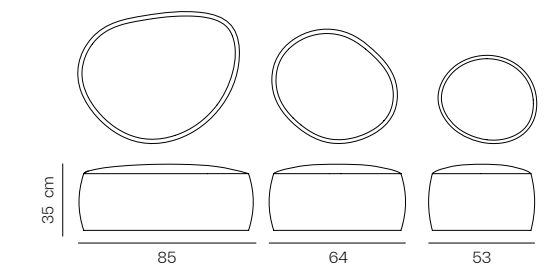

Dimensions
W 85 D 64 H 35 cm big
W 64 D 50 H 35 cm medium
W 53 D 46 H 35 cm small





Bar Stools



Nigiri Bar Stool

Designer Betül İnci

Frame: Solid ash structure
Seat & Back: Upholstered seat and back
Finish: Available in multiple stain colours
*Available in Counter Height

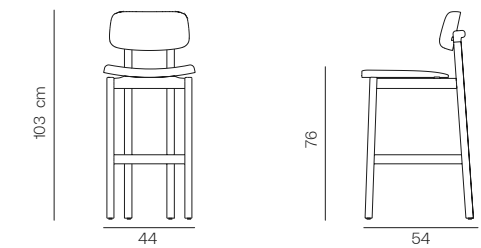

Dimensions

W 44 D 54 H 103 Seat height: 76 cm

Oyster Bar Stool

Designer Enis Altınkaynak

Frame: Plywood back and metal or stainless steel legs (with powder coated metal and coloured steel options)
Seat & Back: Upholstered seat and back
Finish: Available in RAL or steel colours
*Available in Counter Height

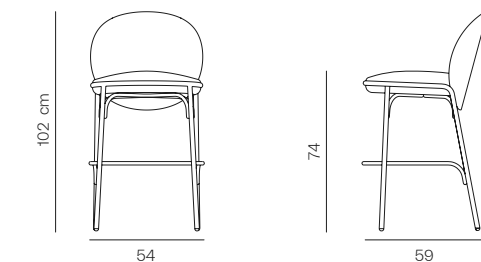

Dimensions

W 54 D 59 H 102 Seat height: 74 cm



Arven Bar Stool

Designer Burcu Özdamar

Frame: Plywood back and solid beech legs, brass, metal or stainless steel arm & footrest (with powder coated metal and coloured steel options)

Seat & Back: Upholstered seat and back

Finish: Available in multiple stain colours, arm & footrest are available in Antique Brass, RAL or steel colours

*Available in Counter Height

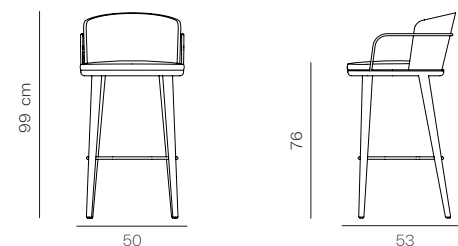

Dimensions

W 50 D 53 H 99 Seat height: 76 cm



Arven L Bar Stool

Designer Burcu Özdamar

Frame: Plywood back and solid beech legs, brass, metal or stainless steel footrest (with powder coated metal and coloured steel options)

Seat & Back: Upholstered seat and back

Finish: Available in multiple stain colours, footrest is available in Antique Brass, RAL or steel colours

*Available in Counter Height

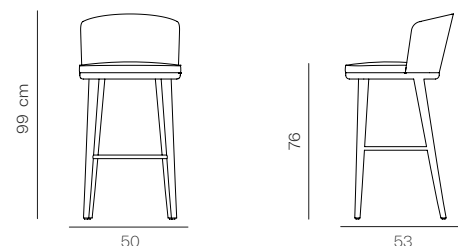

Dimensions

W 50 D 53 H 99 Seat height: 76 cm



L'Esquisse Hotel & Spa Colmar - Colmar, France





Holiday Inn Heathrow - London, UK

Meru Bar Stool

Designer Burcu Özdamar

Frame: Moulded polyurethane back with powder coated metal structure
 Seat & Back: Upholstered seat and back
 Finish: Available in RAL colours

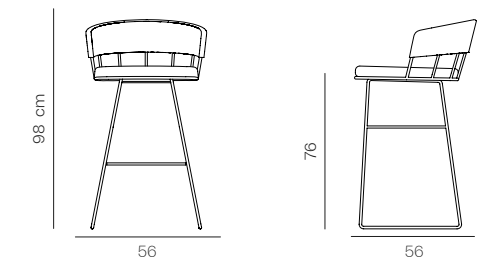

Dimensions

W 56 D 56 H 98 Seat height: 76 cm

Meru L Bar Stool

Designer Burcu Özdamar

Frame: Moulded polyurethane back with powder coated metal structure, footrest and solid beech legs
 Seat & Back: Upholstered seat and back
 Finish: Available in multiple stain colors, back and footrest are available in RAL colours
 *Available in Counter Height

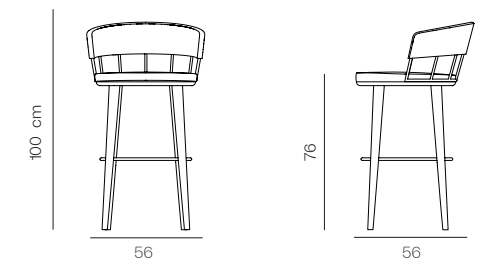

Dimensions

W 56 D 56 H 100 Seat height: 76 cm

Flento Bar Stool

Designers Berrak İlkcan Şener & Yasemin Derici Çeri

Frame: Solid ash and coloured stainless steel legs, coloured stainless steel footrest
Seat: Upholstered genuine leather seat
Finish: Available in steel colours, legs available in multiple stain colours, top available in Relax Series genuine leather colours

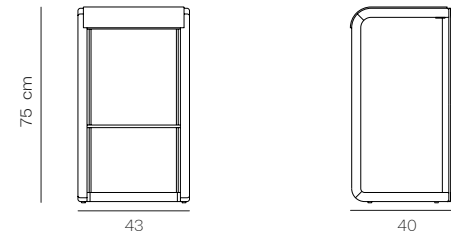

Dimensions

W 43 D 40 H 75 Seat height: 75 cm

Luce Bar Stool

Designer Betül İnci

Frame: Plywood shell and powder coated metal legs
Seat: Upholstered seat
Finish: Available in RAL colours

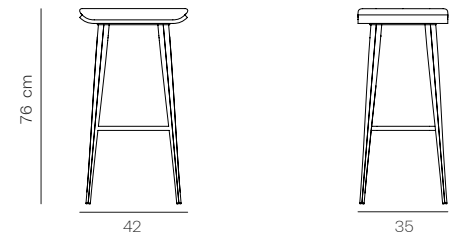

Dimensions

W 42 D 35 H 76 Seat height: 76 cm

Chia Bar Stool

Designer Betül İnci

Frame: Plywood back and metal or stainless steel legs (with powder coated metal and coloured steel options)
Seat & Back: Upholstered seat and back
Finish: Available in RAL or steel colours
*Available in Counter Height

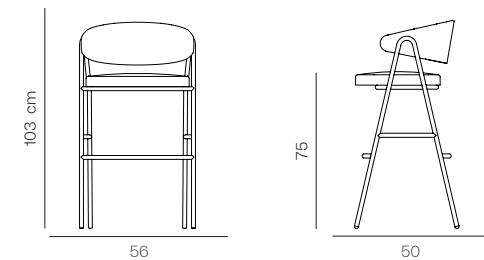

Dimensions

W 56 D 50 H 103 Seat height: 75 cm





Private Office Project- Istanbul, Turkey

Sabien A Bar Stool

Designer David Fox

Frame: Plywood back and solid beech legs
 Seat & Back: Upholstered quilted seat and back
 Finish: Available in multiple stain colours

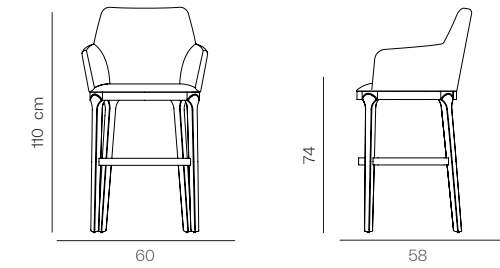

Dimensions

W 60 D 58 H 110 Seat height: 74 cm

Stella Bar Stool

Designer Betül İnci

Finish: Plywood back and solid beech legs, brass, metal or stainless steel footrest (with powder coated metal and coloured steel options)
 Seat & Back: Upholstered seat and back
 Finish: Available in multiple stain colours, footrest available in Antique Brass, RAL or steel colours

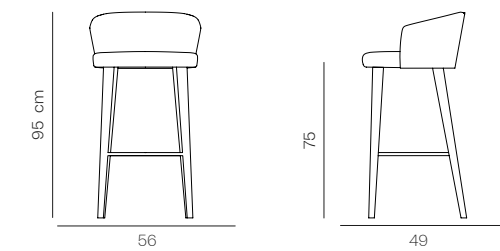

Dimensions

W 56 D 49 H 95 Seat height: 75 cm

Venus Bar Stool

Designer Betül İnci

Frame: Solid beech structure
 Seat & Back: Upholstered seat
 Finish: Available in multiple stain colours
 *Available in Counter Height

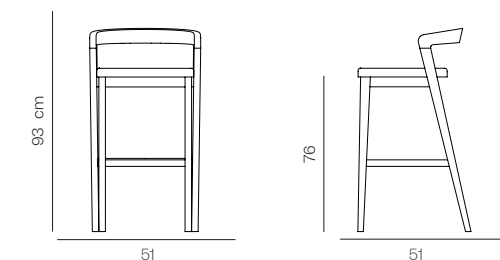

Dimensions

W 51 D 51 H 93 Seat height: 76 cm



Mate Bar Stool

Designer Aysel İlişik

Frame: Beech plywood back and solid beech structure
Seat & Back: Upholstered seat and back
Finish: Available in multiple stain colours
*Available in Counter Height

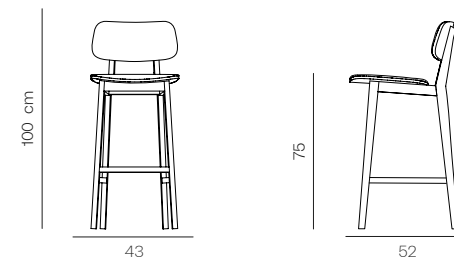

Dimensions

W 43 D 52 H 100 Seat height: 75 cm



Bloom Bar Stool

Designer Betül İnci

Frame: Plywood structure, powder coated metal leg
Seat & Back: Upholstered seat and back
Finish: Available in RAL colours
*Available in Counter Height

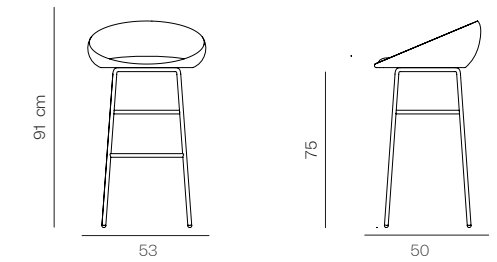

Dimensions

W 53 D 50 H 91 Seat height: 75 cm



Mate V Bar Stool

Designer Aysel İlişik

Frame: Beech plywood back and seat, solid beech structure
Finish: Available in multiple stain colours
*Available in Counter Height

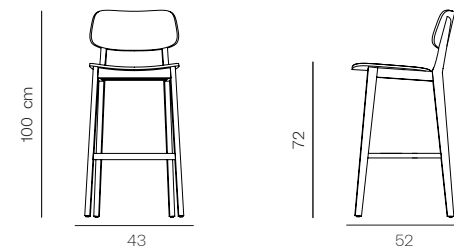

Dimensions

W 43 D 52 H 100 Seat height: 72 cm



Bloom WA Bar Stool

Designer Betül İnci

Frame: Plywood structure and solid beech legs, brass, metal or stainless steel footrest (with powder coated metal and coloured steel options)
Seat & Back: Upholstered seat and back
Finish: Available in multiple stain colours, footrest is available in Antique Brass, RAL or steel colours

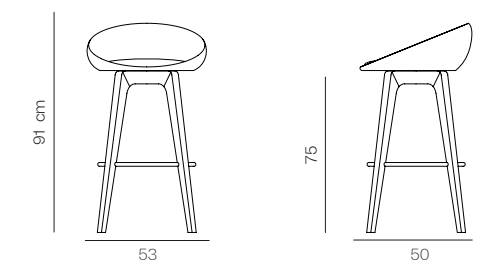

Dimensions

W 53 D 50 H 91 Seat height: 75 cm





Tables

Tofu Table

Designer Seda Yetkiner

Top: Marble top available in Alexander Black, Bruno Perla, Carrara, Emparador Mocca Marbles or Travertine Stone
Leg: Oak veneer base with coloured stainless steel trim base
Finish: Available in multiple stain colours, steel base is available in steel colours

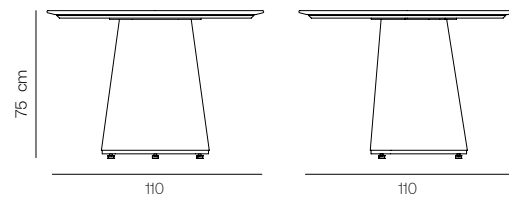

Dimensions
Dia 110 H 75 cm

Roll B Table

Designer Parla Studio

Top: Oak veneer on birch plywood table top
Leg: Powder coated metal leg and base
Finish: Top available in multiple stain colours, leg available in RAL colours

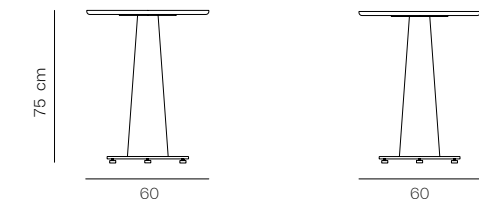

Dimensions
Dia 60 H 75 cm

Tofu V Table

Designer Seda Yetkiner

Top: Oak veneer table top with solid wood edge
Leg: Oak veneer base with coloured stainless steel trim base
Finish: Top and leg available in multiple stain colors, coloured stainless steel trim available in coloured steel colors

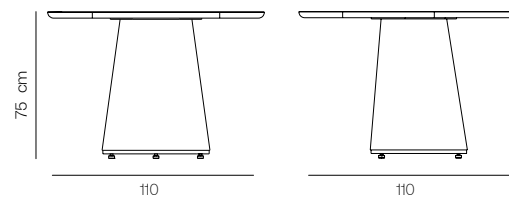

Dimensions
Dia 110 H 75 cm

Tria Table

Designer Betül İnci

Top: Natural oak veneer
Leg: Solid limba legs
Finish: Available in multiple stain colours



Dimensions
W 220 D 100 H 75 cm





Coffee Tables

Blossom Coffee Table



Designer Betül İnci

Top: Cast glass top
Leg: Coloured stainless steel leg and terrazzo base
Finish: Leg available in steel colours

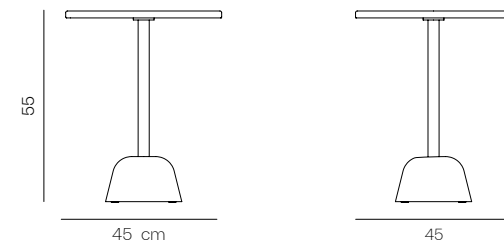

Dimensions
Dia 45 H 55 cm

Tofu Coffee Table



Designer Seda Yetkiner

Top: Clear glass top with coloured stainless steel joinery details, glass available in Extra Clear, Bronze and Smoked Glass options
Leg: Oak veneer with coloured stainless steel base trim
Finish: Leg available in multiple stain colours, steel base trim and joinery detail available in steel colours

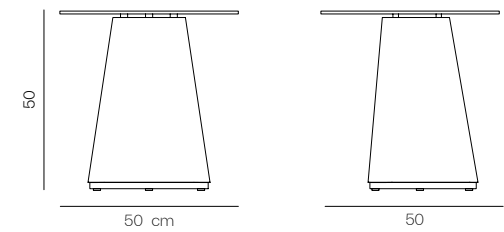

Dimensions
Dia 50 H 50 cm

Tofu V Coffee Table



Designer Seda Yetkiner

Top: Oak veneer on birch plywood table top
Leg: Oak veneer with coloured stainless steel base trim
Finish: Available in multiple stain colours, steel base available in steel colours

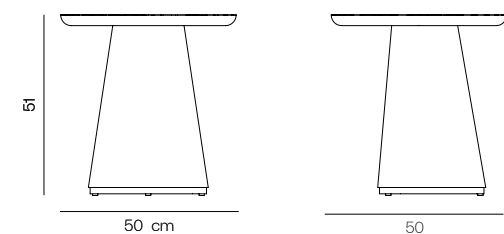

Dimensions
Dia 50 H 51 cm



Mandala Coffee Table



Designer Burcu Özdamar

Top: Tempered glass top available in Extra Clear, Bronze and Smoked glass colours
 Leg: Powder coated metal leg
 Finish: Leg available in RAL colours

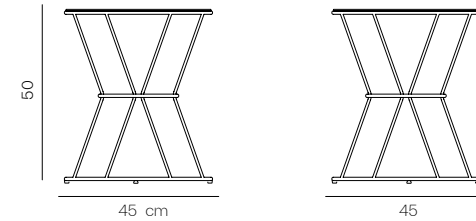

Dimensions
 Dia 45 H 50 cm

Jane M Coffee Table



Designer Parla Studio

Top: Marble top available in Alexander Black, Bruno Perla, Carrara or Emparador Mocca marble or Travertine Stone
 Leg: Powder coated metal leg
 Finish: Available in RAL colours

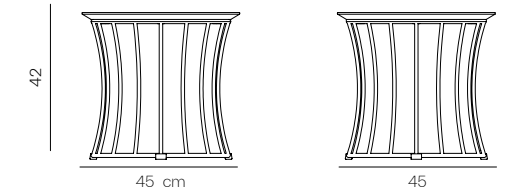

Dimensions
 Dia 45 H 42 cm

Mandala V Coffee Table



Designer Burcu Özdamar

Top: Wood veneer top available in natural walnut veneer or oak veneer with multiple stain colours
 Leg: Powder coated metal leg
 Finish: Leg available in RAL colours

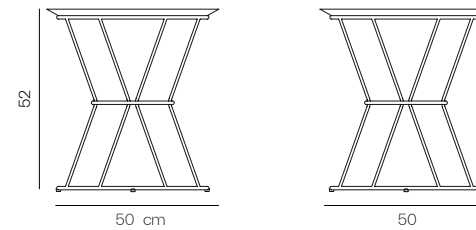

Dimensions
 Dia 50 H 52 cm

Miller Coffee Table



Designer Parla Studio

Top: Wood veneer top available in natural walnut veneer or oak veneer with multiple stain colours
 Leg: Powder coated metal leg
 Finish: Leg available in RAL colours

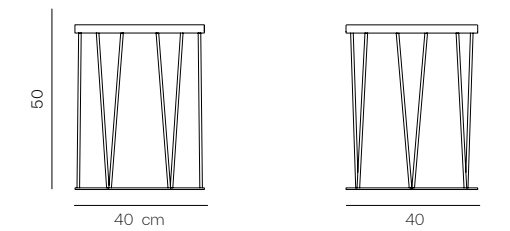

Dimensions
 Dia 40 H 50 cm

Mandala M Coffee Table



Designer Burcu Özdamar

Top: Marble top available in Alexander Black, Bruno Perla, Carrara or Emparador Mocca marble or Travertine Stone
 Leg: Powder coated metal leg
 Finish: Leg available in RAL colours

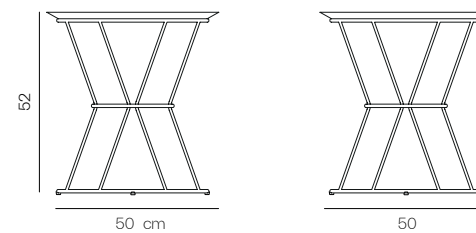

Dimensions
 Dia 50 H 52 cm

Platy Coffee Table



Designer Parla Studio

Top: Wood veneer on birch plywood, available in natural walnut veneer or oak veneer with multiple stain colours
 Leg: Powder coated metal leg
 Finish: Leg available in RAL colours

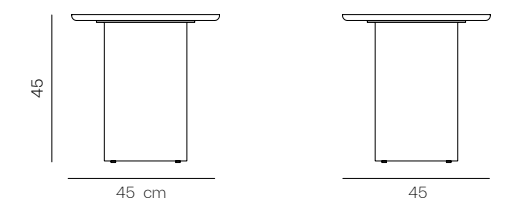

Dimensions
 Dia 45 H 45 cm



Flento Side Table

Designers Berrak İlkcan Şener & Yasemin Derici Çeri

Top: Upholstered genuine leather top
 Leg: Solid ash structure and with coloured stainless steel holder
 Finish: Available in steel colours, legs available in multiple stain colours, top available in Relax Series genuine leather colours

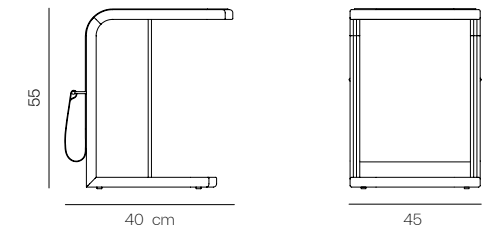

Dimensions
W 40 D 45 H 55 cm

Mawe Low Coffee Table

Designer Yasemin Derici Çeri

Top: Glass top available in Extra Clear, Bronze and Smoked glass colours
 Leg: Marble base available in Alexander Black marble or Travertine Stone

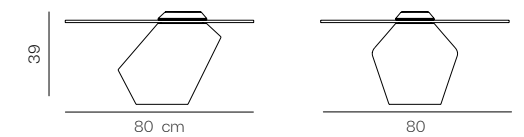

Dimensions
Dia 80 H 39 cm

Mawe Coffee Table

Designer Yasemin Derici Çeri

Top: Glass top available in Extra Clear, Bronze and Smoked glass colours
 Leg: Marble base available in Alexander Black marble or Travertine Stone

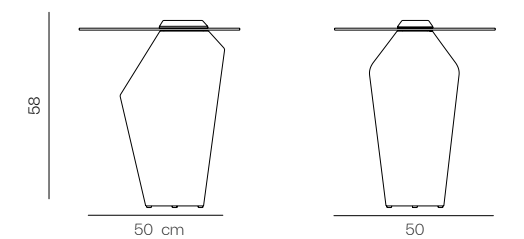

Dimensions
Dia 50 H 58 cm

Bone Coffee Table



Designer Umut Karginoğlu

Top: Marble top available in Alexander Black, Bruno Perla, Carrara or Emparador Mocca marble or Travertine Stone
Leg: Solid beech legs
Finish: Available in multiple stain colours

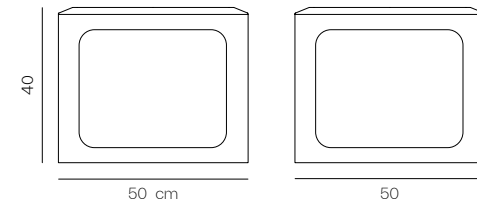

Dimensions
W 50 D 50 H 40 cm

Bone Mid Coffee Table



Designer Umut Karginoğlu

Top: Marble top available in Alexander Black, Bruno Perla, Carrara or Emparador Mocca marble or Travertine Stone
Leg: Solid beech legs
Finish: Available in multiple stain colours

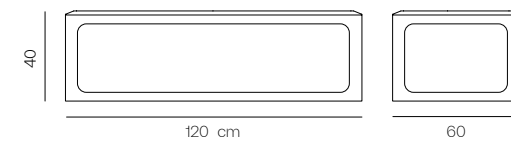

Dimensions
W 120 D 60 H 40 cm

London High Coffee Table



Designer Burcu Özdamar

Top: Wood veneer top available in natural walnut veneer or oak veneer with multiple stain colours
Leg: Metal or stainless steel legs (with powder coated metal and coloured steel options)
Finish: Available in multiple stain colours, legs available in RAL or steel colours

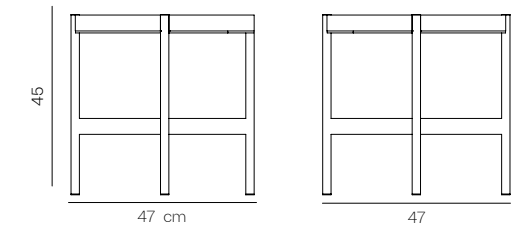

Dimensions
Dia 47 H 45 cm

London Mid Coffee Table



Designer Burcu Özdamar

Top: Wood veneer top available in natural walnut veneer or oak veneer with multiple stain colours
Leg: Metal or stainless steel legs (with powder coated metal and coloured steel options)
Finish: Available in multiple stain colours, legs available in RAL or steel colours

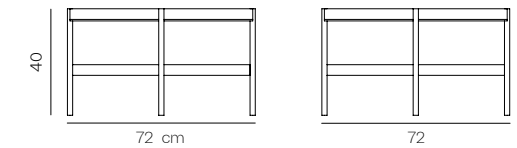

Dimensions
Dia 72 H 40 cm

London Low Coffee Table



Designer Burcu Özdamar

Top: Wood veneer top available in natural walnut veneer or oak veneer with multiple stain colours
Leg: Metal or stainless steel legs (with powder coated metal and coloured steel options)
Finish: Available in multiple stain colours, legs available in RAL or steel colours

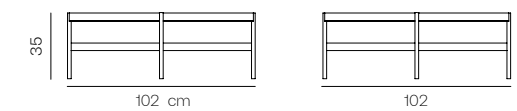

Dimensions
Dia 102 H 35 cm

Oyster Coffee Table



Designer Enis Altinkaynak

Top: Marble top available in Alexander Black, Bruno Perla, Carrara, Emparador Mocca marbles or Travertine Stone
Leg: Solid ash legs
Finish: Legs available in multiple stain colours

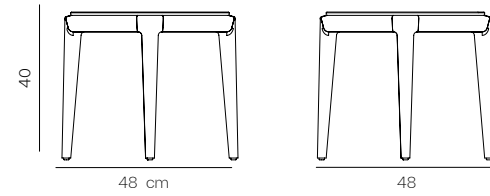

Dimensions
Dia 48 H 40 cm

Oyster V Coffee Table



Designer Enis Altinkaynak

Top: Ash veneer table top
Leg: Solid ash legs
Finish: Legs available in multiple stain colours

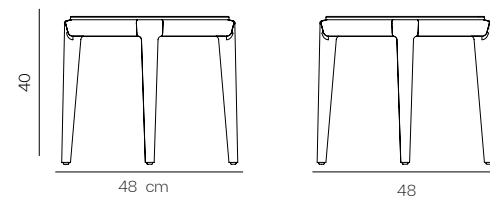

Dimensions
Dia 48 H 40 cm

Goba Coffee Table



Designer Esin Sözen Kalender

Top: Marble top available in Alexander Black, Bruno Perla, Carrara, Emparador Mocca marbles or Travertine Stone
Leg: Solid beech legs
Finish: Available in multiple stain colours

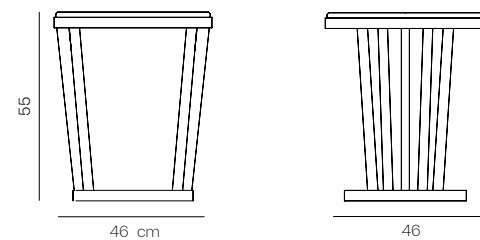

Dimensions
Dia 46 H 55 cm







Sofas

Hug Sofa

Designer Betül İnci

Frame: Plywood and solid beech structure, oak wood base
Seat & Back: Upholstered seat and back
Finish: Available in multiple stain colours

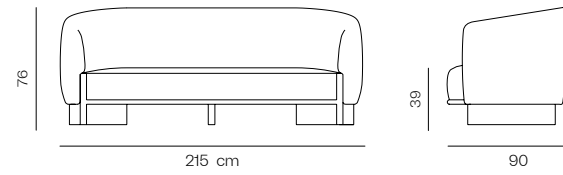

Dimensions

W 200 D 83 H 75 Seat height: 38 cm

London Sofa

Designer Burcu Özdamar

Frame: Plywood and solid beech structure, wood veneer base and metal or stainless steel legs (with powder coated metal or coloured steel options)
Seat & Back: Upholstered seat, back and cushions
Finish: Base is available in natural walnut or oak veneer with multiple stain colours, legs are available in RAL or steel colours

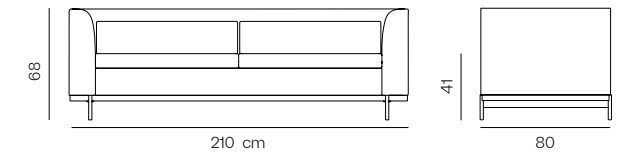

Dimensions

W 210 D 80 H 68 Seat height: 41 cm

Grace Sofa

Designer Betül İnci

Frame: Plywood and solid beech structure
Seat & Back: Upholstered seat, back and cushions

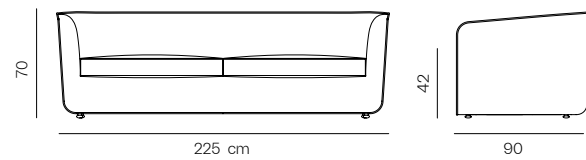

Dimensions

W 225 D 90 H 70 Seat height: 42 cm

Goba Sofa

Designer Esin Sözen Kalender

Frame: Solid beech structure
Seat & Back: Upholstered seat and back cushions
Finish: Available in multiple stain colours

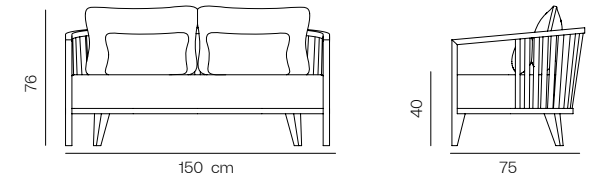

Dimensions

W 150 D 75 H 76 Seat height: 40 cm



Luce Sofa



Designer Betül İnci

Frame: Plywood and solid beech structure, powder coated metal legs
Seat & Back: Upholstered seat and back
Finish: Available in RAL colours

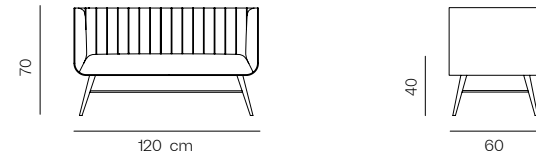

Dimensions

W 120 D 60 H 70 Seat height: 40 cm

Net Sofa



Designer Betül İnci

Frame: Plywood and solid beech structure
Seat & Back: Upholstered seat and inner back, woven banana fiber back
Finish: Available in multiple stain colours

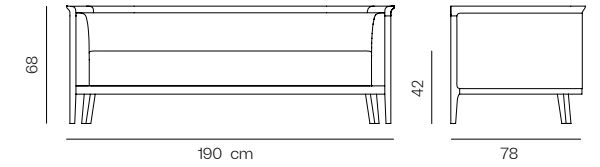

Dimensions

W 190 D 78 H 68 Seat height: 42 cm

Atlas Sofa



Designer Betül İnci

Frame: Plywood and solid beech structure, solid beech legs
Seat & Back: Upholstered seat and back
Finish: Available in multiple stain colours

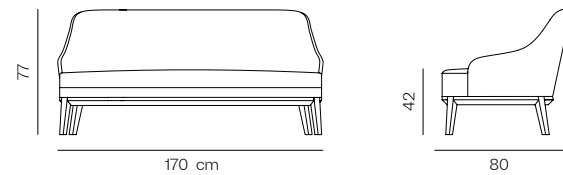

Dimensions

W 170 D 80 H 77 Seat height: 42 cm

Net WF Sofa



Designer Betül İnci

Frame: Plywood and solid beech structure
Seat & Back: Upholstered seat, inner and outer back
Finish: Available in multiple stain colours

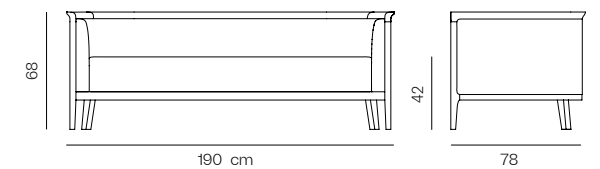

Dimensions

W 190 D 78 H 68 Seat height: 42 cm



Estival Sofa

Designer Parla Studio

Frame: Plywood and solid beech structure, powder coated metal base
 Seat & Back: Upholstered seat, back and cushions
 Finish: Available in RAL colours

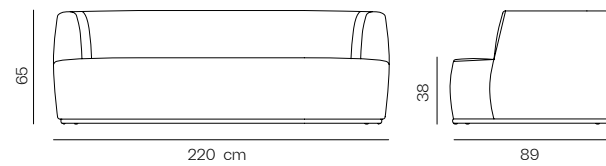

Dimensions

W 220 D 89 H 65 Seat height: 38 cm

Estival L Sofa

Designer Parla Studio

Frame: Plywood and solid beech structure, powder coated metal base
 Seat & Back: Upholstered seat, back and cushions
 Finish: Available in RAL colours expansion available for Left or Right directions

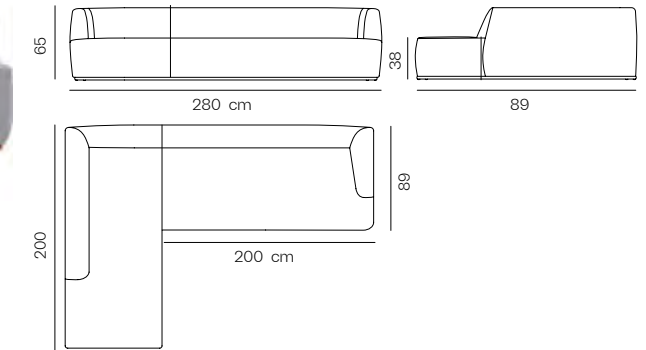

Dimensions

W 280+200 D 89 H 65 Seat height: 38 cm

Petra Sofa

Designer Betül İnci

Frame: Plywood and solid beech structure, powder coated metal legs
 Seat & Back: Upholstered seat and back
 Finish: Available in RAL colours

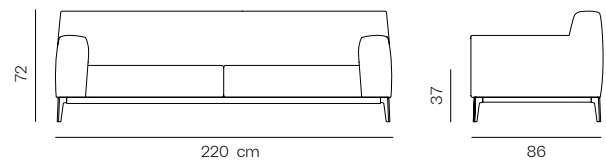

Dimensions

W 220 D 86 H 72 Seat height: 37 cm

Petra L Sofa

Designer Betül İnci

Frame: Plywood and solid beech structure, powder coated metal legs
 Seat & Back: Upholstered seat and back
 Finish: Available in RAL colours expansion available for Left or Right directions

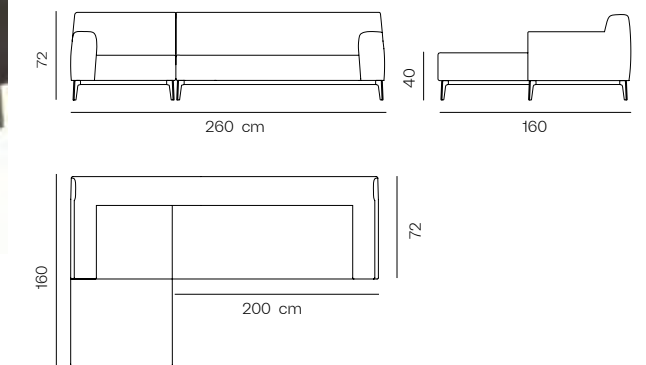

Dimensions

W 260+160 D 87 H 72 Seat height: 40 cm



Outdoor



Morwi A Chair



Designer Berrak İlkcan Şener

Frame: Powder coated metal structure with outdoor treatment, back structure woven with PE rope
 Seat & Back: Upholstered seat cushion
 Finish: Frame available in RAL colours, rope is available in Grey white, Antracite Grey, Lemon Verbena and Vermillion Red

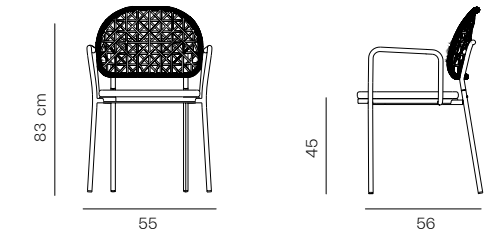

Dimensions
 W 55 D 56 H 83 Seat height: 45 cm

Morwi Chair



Designer Berrak İlkcan Şener

Frame: Powder coated metal structure with outdoor treatment, back woven with PE rope
 Seat & Back: Upholstered seat cushion
 Finish: Frame available in RAL colours, rope available in Grey White, Antracite Grey, Lemon Verbena and Vermillion Red

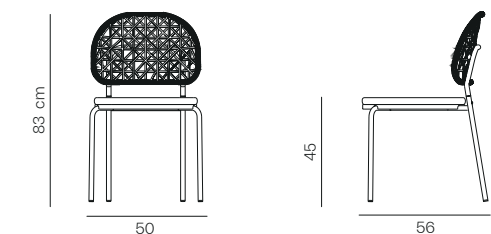

Dimensions
 W 50 D 56 H 83 Seat height: 45 cm

Iona Chair



Designer Deniz Albayrak

Frame: Powder coated metal structure with outdoor treatment, back structure woven with polyester rope available in black, tan and khaki rope colours
Seat & Back: Solid iroko base and PVC seat with upholstered seat cushion
Finish: Available in RAL colours with outdoor treatment, base available in natural iroko colour

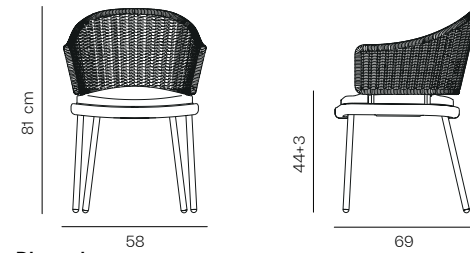

Dimensions

W 58 D 69 H 81 Seat height: 44+3 cm cushion

Tanin Chair



Designer Erden Dereli

Frame: Powder coated metal structure
Seat & Back: Solid iroko seat, woven with polyester rope back available in black, tan and khaki rope colours
Finish: Leg available in RAL colours with outdoor treatment, seat in natural iroko colour

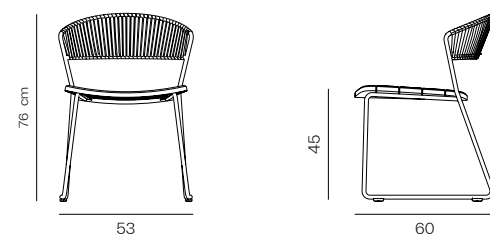

Dimensions

W 53 D 60 H 76 Seat height: 45 cm





Svelte T Chair



Designer Umut Karginoğlu

Frame: Solid iroko structure
Seat & Back: Upholstered seat and back cushion
Finish: Available in natural iroko colour

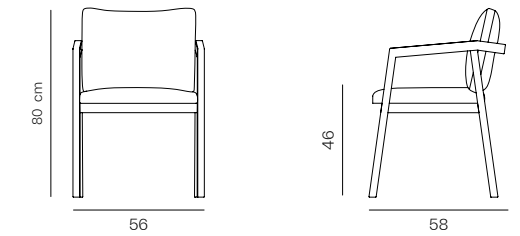

Dimensions
W 56 D 58 H 80 Seat height: 46 cm

Akka Chair



Designer Klan Studio

Frame: Powder coated aluminium structure, solid iroko arms and legs
Seat & Back: Upholstered seat and back cushions
Finish: Available in RAL colours with outdoor treatment, legs and arms available in natural iroko colour

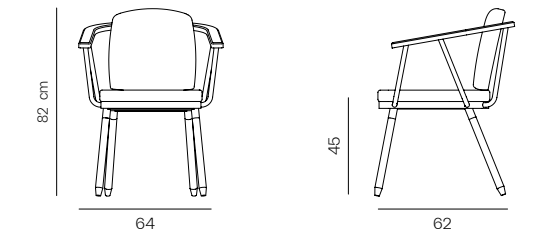

Dimensions
W 64 D 62 H 82 Seat height: 45 cm

Venus XL T Chair



Designer Betül İnci

Frame: Solid iroko structure
Seat & Back: Upholstered seat and back woven with PE rope
Finish: Available in natural iroko colour

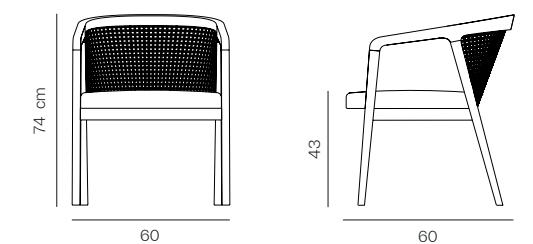

Dimensions
W 60 D 60 H 74 Seat height: 43 cm



Four Seasons Hotel Istanbul at Sultanahmet - Istanbul, Turkey

Chia E Chair



Designer Betül İnci

Frame: Powder coated aluminium structure, woven back with polyester rope available in black, tan and khaki rope colours
Seat & Back: Upholstered seat cushion
Finish: Available in RAL colours with outdoor treatment

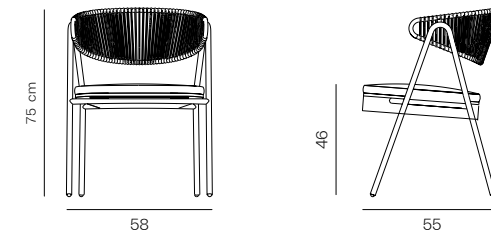

Dimensions

W 58 D 55 H 75 Seat height: 46 cm

Capri Chair



Designer Betül İnci

Frame: Powder coated aluminium structure woven with polyester rope available in black, tan and khaki rope colours
Seat & Back: Upholstered seat and back cushion
Finish: Available in RAL colours with outdoor treatment

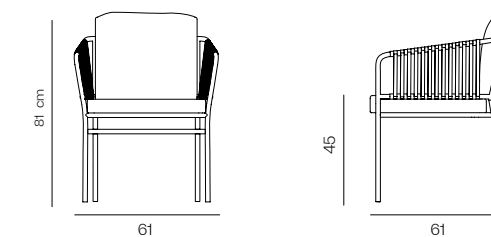

Dimensions

W 61 D 61 H 81 Seat height: 45 cm



Rixos Premium Dubai JBR - Dubai, UAE

Capri Lounge Armchair



Designer Betül İnci

Frame: Powder coated aluminium structure woven with polyester rope available in black, tan and khaki rope colours
Seat & Back: Upholstered seat and back cushion
Finish: Available in RAL colours with outdoor treatment

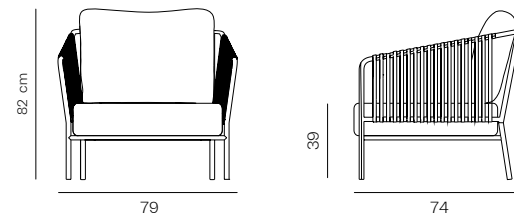

Dimensions

W 79 D 74 H 82 Seat height: 39 cm

Svelte T Armchair



Designer Umut Kargınoğlu

Frame: Solid iroko structure
Seat & Back: Upholstered seat and back cushion
Finish: Available in natural iroko colour

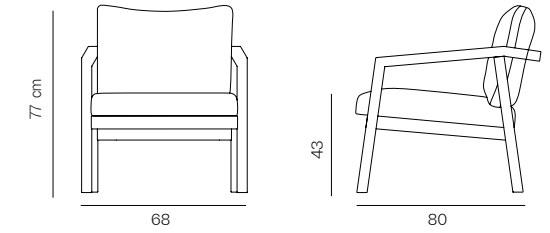

Dimensions

W 68 D 80 H 77 Seat height: 43 cm

Bloom E Club Armchair



Designer Betül İnci

Frame: Solid iroko legs and metal structure woven with polyester rope available in black, tan and khaki rope colours
Seat & Back: Upholstered seat and back cushions
Finish: Available in natural iroko colour

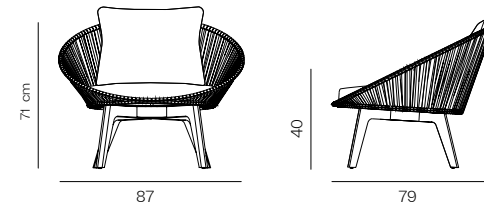

Dimensions

W 87 D 79 H 71 Seat height: 40 cm

Goba T Armchair



Designer Esin Sözen Kalender

Frame: Solid iroko structure
Seat & Back: Upholstered seat and back cushion
Finish: Available in natural iroko colour

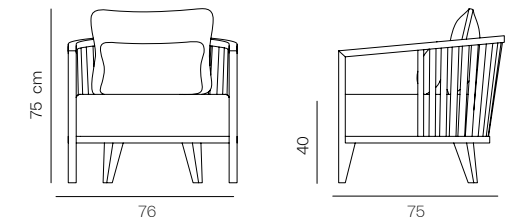

Dimensions

W 76 D 75 H 75 Seat height: 40 cm



Pınar Hotel - Balıkesir, Turkey

Bloom E Bar Stool

Designer Betül İnci

Frame: Powder coated metal structure woven with polyester rope available in black, tan and khaki rope colours
 Seat: Upholstered seat
 Finish: Available in RAL colours with outdoor treatment
 * Available in counterheight

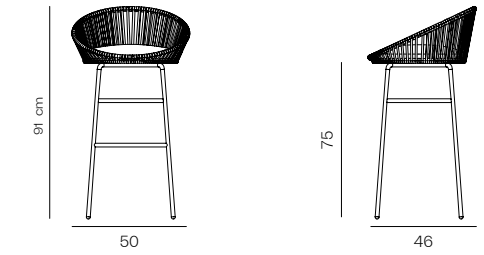

Dimensions
W 50 D 46 H 91 Seat height: 75 cm

Capri Bar Stool

Designer Betül İnci

Frame: Powder coated aluminium structure woven with polyester rope available in black, tan and khaki rope colours
 Seat & Back: Upholstered seat and back cushion
 Finish: Available in RAL colours with outdoor treatment
 * Available in counterheight

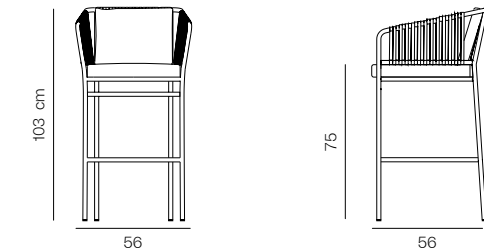

Dimensions
W 56 D 56 H 103 Seat height: 75 cm

Morwi Bar Stool

Designer Berrak İlkcan Şener

Frame: Powder coated metal structure with outdoor treatment, back structure woven with PE rope
 Seat & Back: Upholstered seat cushion
 Finish: Frame available in RAL colours, rope is available in Grey white, Antracite Grey, Lemon Verbena and Vermillion Red
 * Available in counterheight

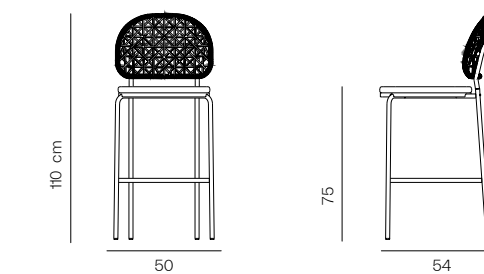

Dimensions
W 50 D 54 H 110 Seat height: 75 cm

Svelte T Sofa



Designer Umut Kargınoğlu

Frame: Plywood and solid beech structure, natural wood veneer base and powder coated metal or coloured steel leg
Seat & Back: Upholstered seat, back and cushions
Base is available in walnut or oak veneer with multiple stain colours, legs are available in RAL colours or coloured steel finishes

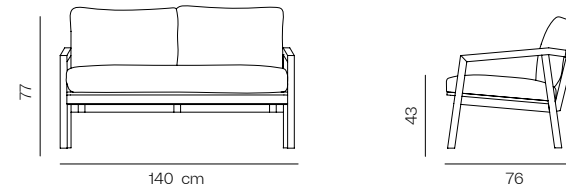

Dimensions

W 140 D 76 H 77 Seat height: 43 cm

Goba T Sofa



Designer Esin Sözen Kalender

Frame: Solid beech structure
Seat & Back: Upholstered seat and back cushions
Finish: Available in multiple stain colours

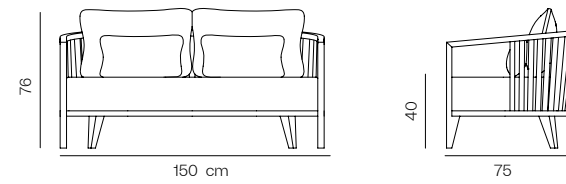

Dimensions

W 150 D 75 H 76 Seat height: 40 cm

Goba T Coffee Table



Designer Esin Sözen Kalender

Top: Marble top available in Alexander Black, Bruno Perla, Carrara, Emparador Mocca marbles or Travertine Stone
Leg: Solid iroko
Finish: Available in natural iroko colour

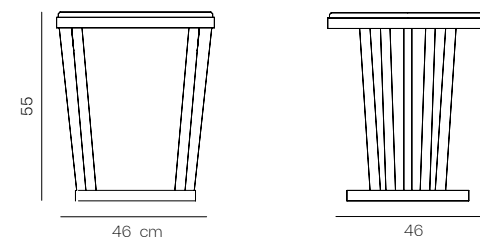

Dimensions

Dia 46 H 55 cm



Sofitel - Istanbul, Turkey



Storage & Consoles

Flento Console



Designer Berrak İlkcan Şener & Yasemin Derici Çeri

Top: Upholstered genuine leather top
Frame: Solid ash and coloured stainless steel legs
Finish: Available in steel colours, legs available in multiple stain colours. Top available in Bitter and Cinnamon

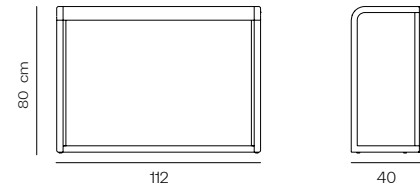

Dimensions
W 112 D 40 H 80 cm

Rain Small Console



Designer Buket Hoşcan Bazman

Body: Oak veneer cabinet with glass doors & metal handle & legs
Finish: Available in multiple stain colours, legs available in coloured steel colours.

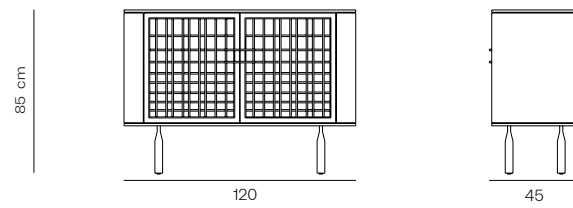

Dimensions
W 120 D 45 H 85 cm

Rain Console



Designer Buket Hoşcan Bazman

Body: Oak veneer cabinet with glass doors and metal handle & legs
Finish: Available in multiple stain colours, legs available in coloured steel colours

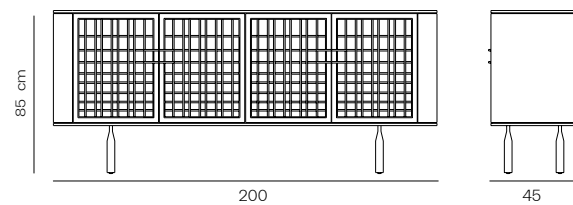

Dimensions
W 200 D 45 H 85 cm





Product List by Category

Chairs



Atlas A Chair
Pg: 45



Atlas Chair
Pg: 45



Arven Chair
Pg: 37



Arven L Chair
Pg: 37



Oyster W Chair
Pg: 38



Oyster WA Chair
Pg: 38



Remus Chair
Pg: 52



Remus S Chair
Pg: 52



Chia Chair
Pg: 42



Fau A Chair
Pg: 29



Gala V Chair
Pg: 32



Kybele WF Chair
Pg: 41



Ren Chair
Pg: 51



Ren P Chair
Pg: 51



Rimo Chair
Pg: 42



Sabien A Chair
Pg: 55



Luna A Chair
Pg: 52



Mate XL Chair
Pg: 48



Mate XL V Chair
Pg: 48



Meru Chair
Pg: 41



Sabien Chair
Pg: 55



Stella Chair
Pg: 56



Stella V Chair
Pg: 56



Stella W Chair
Pg: 56



Meru L Chair
Pg: 41



Mod Chair
Pg: 55



Mod S Chair
Pg: 61



Mod RS Chair
Pg: 61



Venus A Chair
Pg: 32



Venus Chair
Pg: 32



Mod W Chair
Pg: 61



Nigiri Chair
Pg: 29



Olive Chair
Pg: 45



Oyster Chair
Pg: 38

Armchairs



Atlas Armchair
Pg: 70



Atlas V Armchair
Pg: 70



Bloom Club Armchair
Pg: 75



Estival Armchair
Pg: 79



Eve Wing Back Armchair
Pg: 69



Goba Armchair
Pg: 76



Hug Armchair
Pg: 65



Luce Armchair
Pg: 79



Milla Armchair
Pg: 79



Moose Armchair
Pg: 65



Net Armchair
Pg: 65



Net WF Armchair
Pg: 76



Oyster W Armchair
Pg: 66



Padova Armchair
Pg: 75



Padova U Armchair
Pg: 75



Remus Armchair
Pg: 70



Rimo Armchair
Pg: 66



Xaylon W Armchair
Pg: 69



Xaylon Armchair
Pg: 69

Coffee Tables



Blossom Coffee Table
Pg: 112



Bone Coffee Table
Pg: 118



Bone Mid Coffee Table
Pg: 118



Fliento Side Table
Pg: 117



Goba Coffee Table
Pg: 120



Jane M Coffee Table
Pg: 115



London High Coffee Table
Pg: 119



London Low Coffee Table
Pg: 119



London Mid Coffee Table
Pg: 119



Mandala Coffee Table
Pg: 114



Mandala M Coffee Table
Pg: 114



Mandala V Coffee Table
Pg: 114



Mawe Coffee Table
Pg: 117



Mawe Low Coffee Table
Pg: 117



Miller Coffee Table
Pg: 115



Oyster Coffee Table
Pg: 120



Oyster V Coffee Table
Pg: 120



Platy Coffee Table
Pg: 115



Tofu Coffee Table
Pg: 112



Tofu V Coffee Table
Pg: 112

Bar Stools



Arven Bar Stool
Pg: 90



Arven L Bar Stool
Pg: 90



Bloom Bar Stool
Pg: 101



Bloom WA Bar Stool
Pg: 101



Chia Bar Stool
Pg: 96



Flento Bar Stool
Pg: 96



Luce Bar Stool
Pg: 96



Mate Bar Stool
Pg: 100



Mate V Bar Stool
Pg: 100



Meru Bar Stool
Pg: 95



Meru L Bar Stool
Pg: 95



Nigiri Bar Stool
Pg: 89



Oyster Bar Stool
Pg: 89



Sabien Bar Stool
Pg: 99



Stella Bar Stool
Pg: 99



Venus Bar Stool
Pg: 99

Stools & Poufs



Atlas Pouf
Pg: 82



London Pouf
Pg: 82



Luce Foot Stool
Pg: 83



Luce Stool
Pg: 83



Remus Pouf
Pg: 82



Rocks Pouf
Pg: 83

Tables



Roll B Table
Pg: 107



Tofu V Table
Pg: 106



Tofu Table
Pg: 106



Tria Table
Pg: 107

Sofas



Atlas Sofa
Pg: 130



Estival Sofa
Pg: 134



Estival L Sofa
Pg: 135



Goba Sofa
Pg: 127



Grace Sofa
Pg: 126



Hug Sofa
Pg: 126



London Sofa
Pg: 127



Luce Sofa
Pg: 130



Net Sofa
Pg: 131



Net WF Sofa
Pg: 131



Petra Sofa
Pg: 134



Petra L Sofa
Pg: 135

Storage & Consoles



Flento Console
Pg: 156



Rain Console
Pg: 156



Rain Small Console
Pg: 156

Outdoor



Akka Chair
Pg: 143



Capri Chair
Pg: 146



Chia E Chair
Pg: 146



Iona Chair
Pg: 140



Morwi A Chair
Pg: 139



Morwi Chair
Pg: 139



Svelte Chair
Pg: 143



Tanin Chair
Pg: 140



Venus XL T Chair
Pg: 143



Bloom E Bar Stool
Pg: 151



Capri Bar Stool
Pg: 151



Morwi Bar Stool
Pg: 151



Bloom E Club Armchair
Pg: 148



Capri Armchair
Pg: 148



Goba T Armchair
Pg: 149



Svelte T Armchair
Pg: 149



Goba T Sofa
Pg: 152



Svelte T Sofa
Pg: 152



Goba T Coffee Table
Pg: 152



Materials & Colours

Solid Wood

Ash

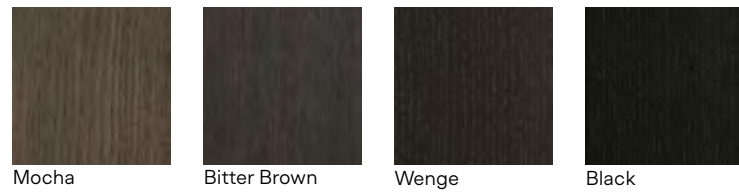
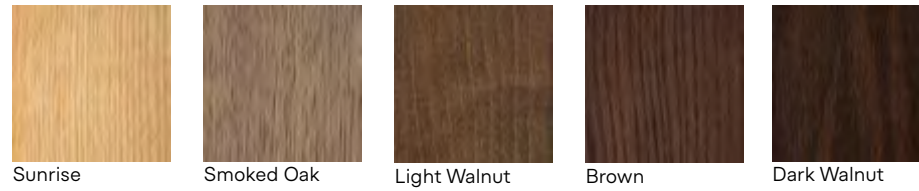

Beech

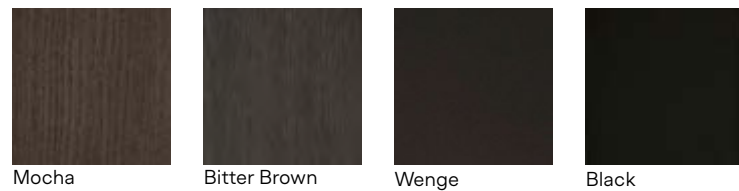
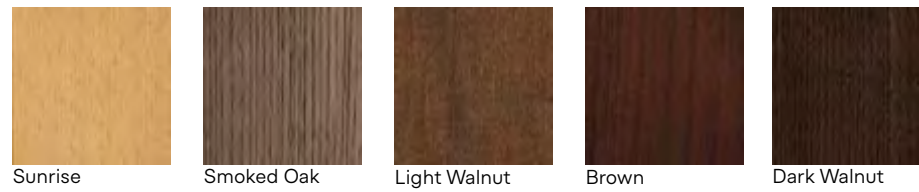

Wood Veneer

Oak

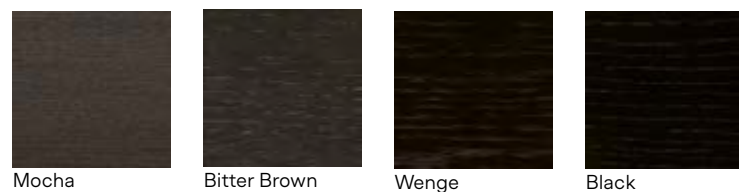
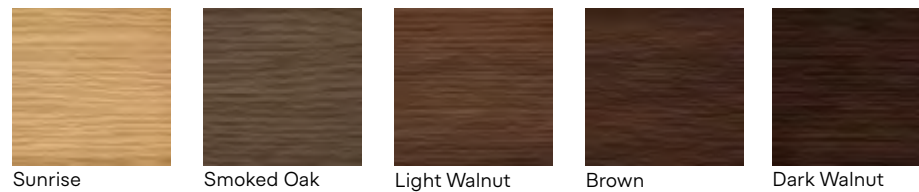

American Walnut

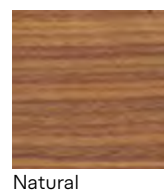

*We use quarter cut veneer sheets with slip matching on plywood as our standard for wood veneer options.

Metal

Brass

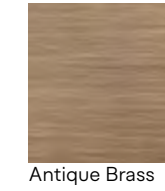

Powder Coated Matte

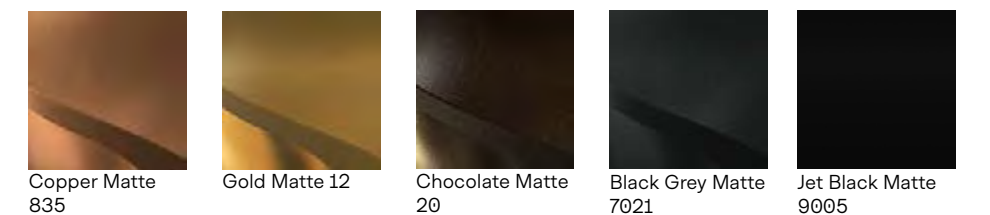

Coloured Steel

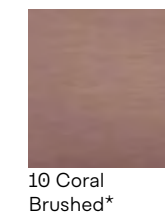

* This finish requires an additional 2 weeks for production.

Glass & Stone

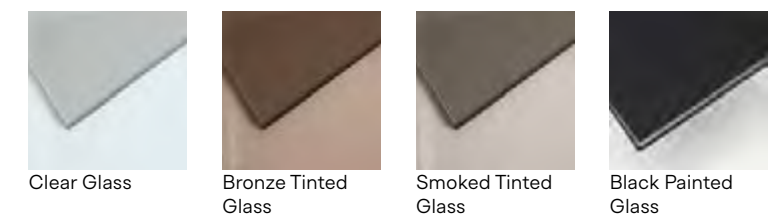
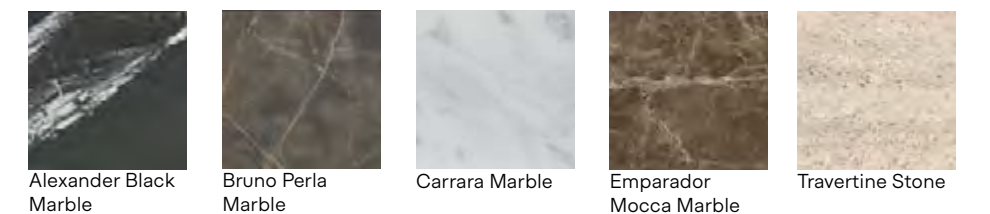

Outdoor

Iroko



Natural*

* Direct exposure to sunlight will eventually affect Iroko's colour, creating a darker shade in time.

Powder Coated Textured

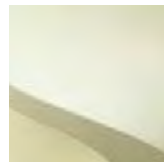

Oyster White Textured 1013



Grey White Textured 9002



Pure White Textured 9010

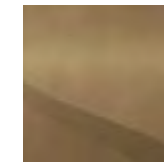

Grey Beige Textured 1019

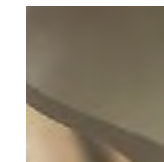

Peanut Textured 967

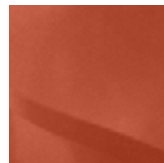

Salmon Orange Textured 2012

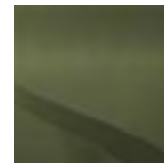

Reed Green Textured 6013

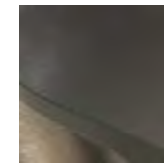

Earth Textured 39

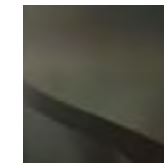

Stone Grey Textured 7030

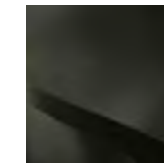

Umbr Grey Textured 7022

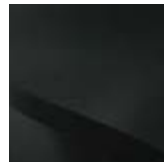

Black Grey Textured 7021

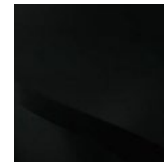

Jet Black Textured 9005

Rope

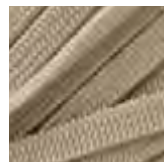

Flat Rope Tan

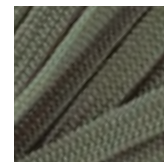

Flat Rope Khaki

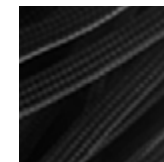

Flat Rope Black



Woven Rope Tan

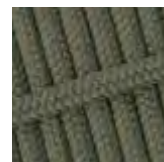

Woven Rope Khaki



Woven Rope Black



Grey White GR10



Lemon Verbena K10



Vermilion TR17



Anthracite Grey GR23

Upholstery / Fabric

Category A

Athena



1131



1144



1152



1158



1192



1203

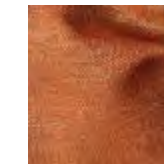

1209

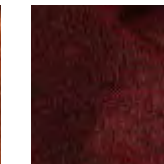

1212

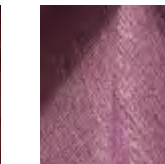

1215

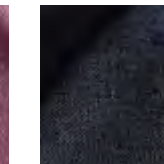

1225



1230

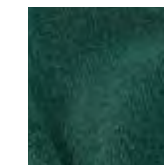

1238

Category A

Velluto

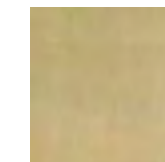

K18010

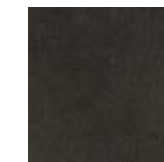

K180J3

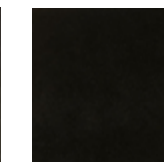

K1848

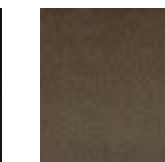

K180T8

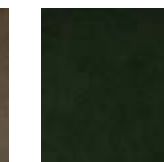

K180BM

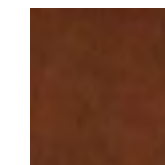

K1821

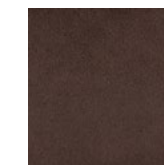

K180R7

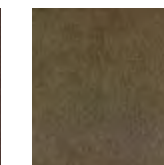

K180N9



K180K7

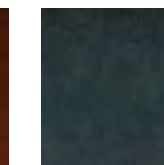

K180E2

Category B

Aspect

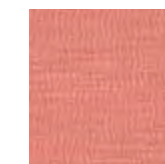

ACT07



ACT08



ACT09



ACT12



ACT14



ACT15



ACT17



ACT29



ACT30



ACT31

Category B

Magician



Category B

Winston

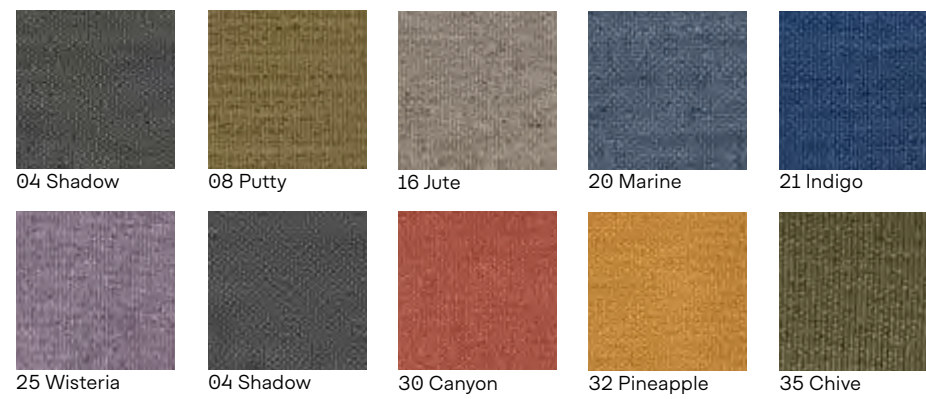

Category B

Teddy

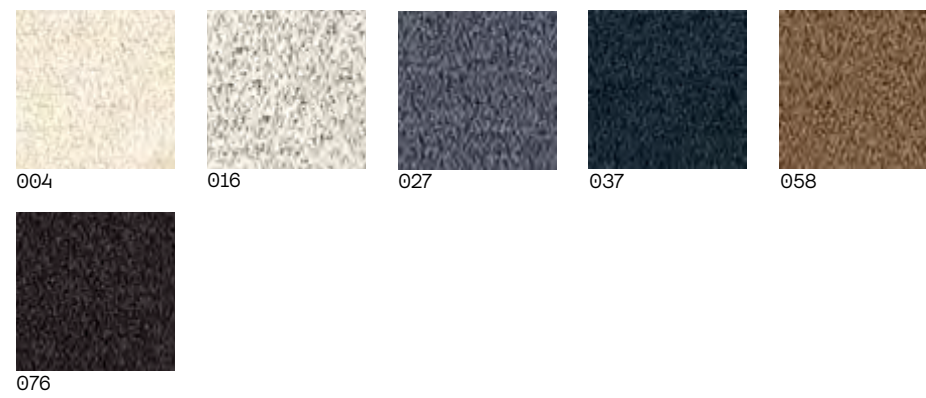

Category B

Rizo



Category B

Nino

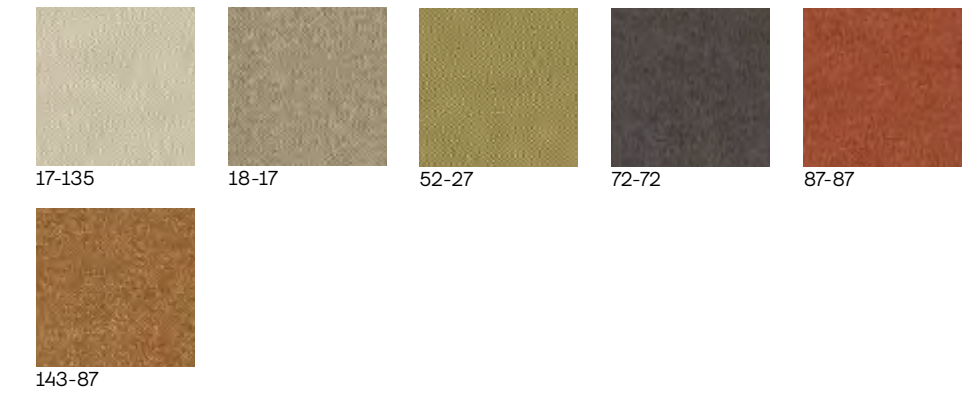

Category B

New Sabine



Category C

Main Line Flax

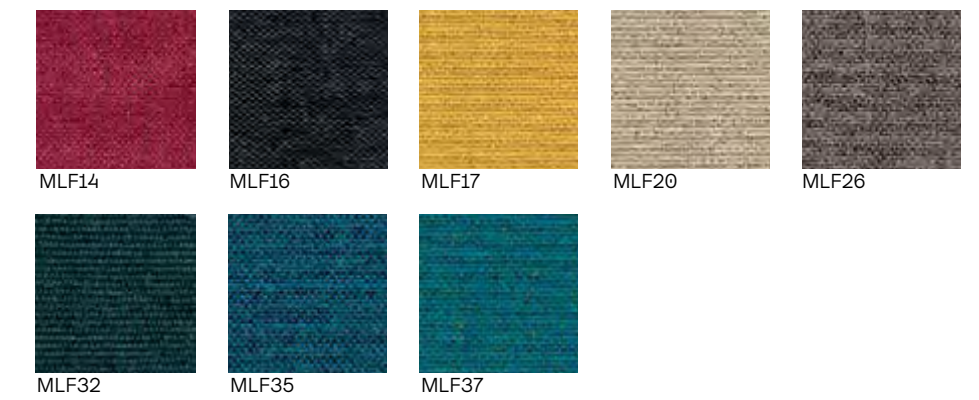

Category C

Loft



Category C

Bolt



Category D

Remix 3

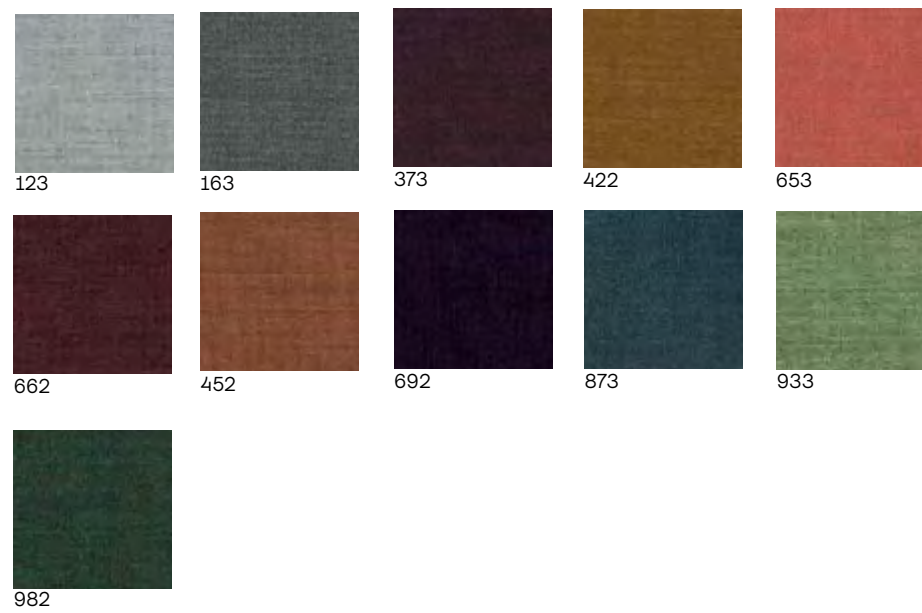

Category E

Steelcut Trio

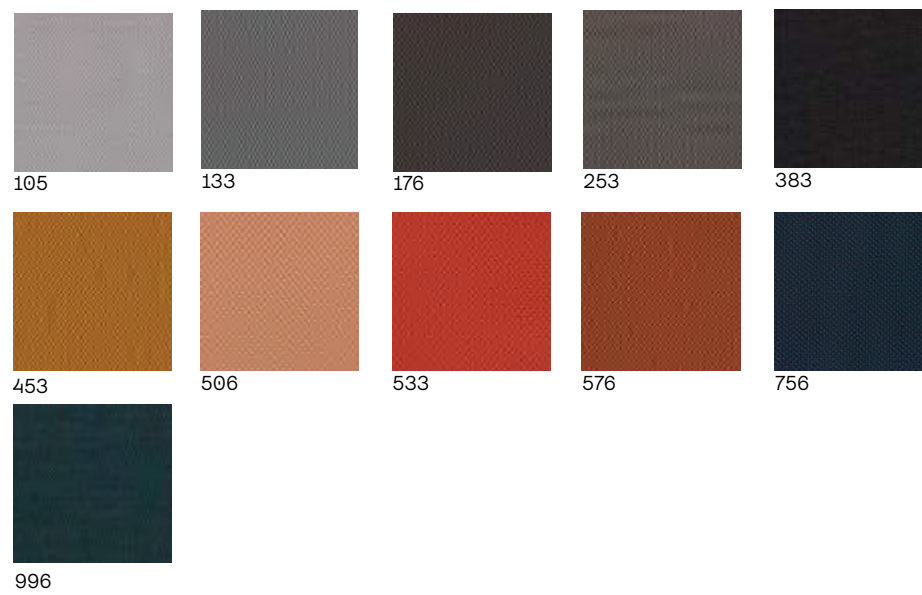

Category E

Hallingdal 65

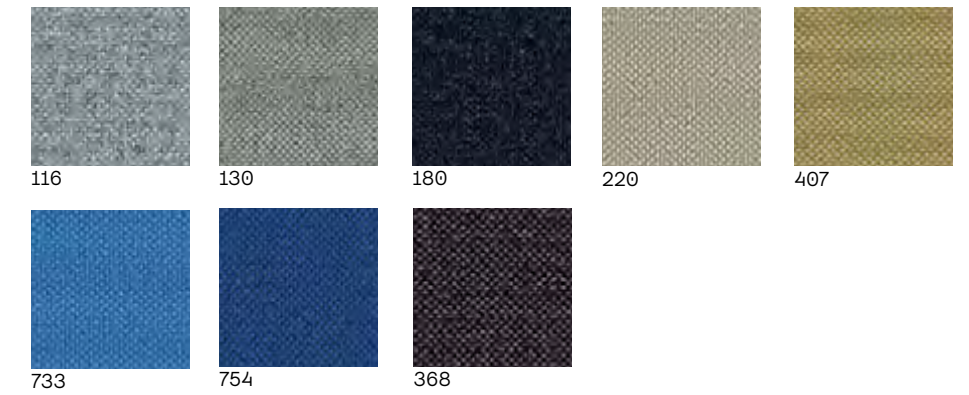

Upholstery / Outdoor

Category A

Malta 02

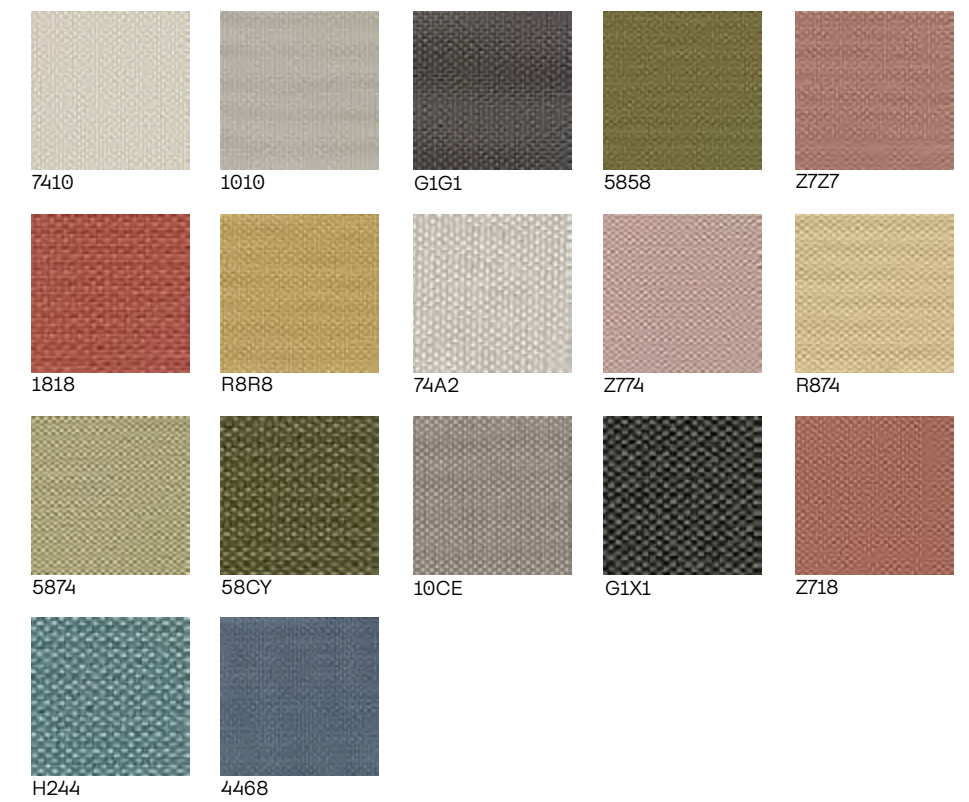

Category C

P Heritage



Category D

S Heritage



Category D

Patio

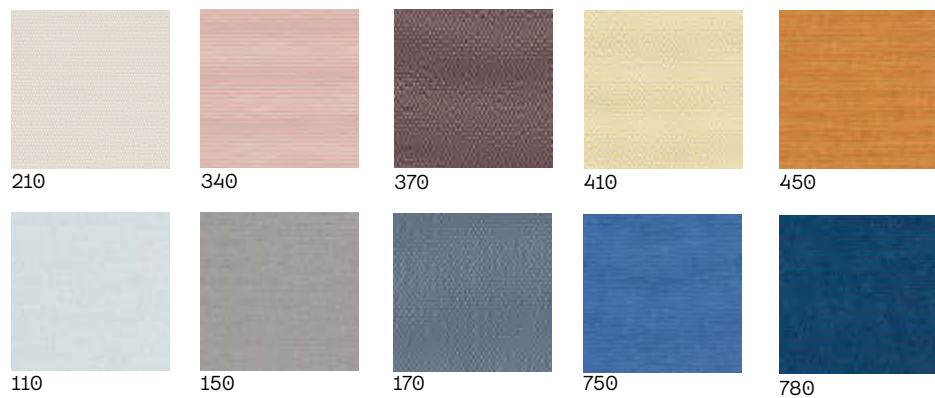

Upholstery / Artificial Leather

Category A

Nona FR

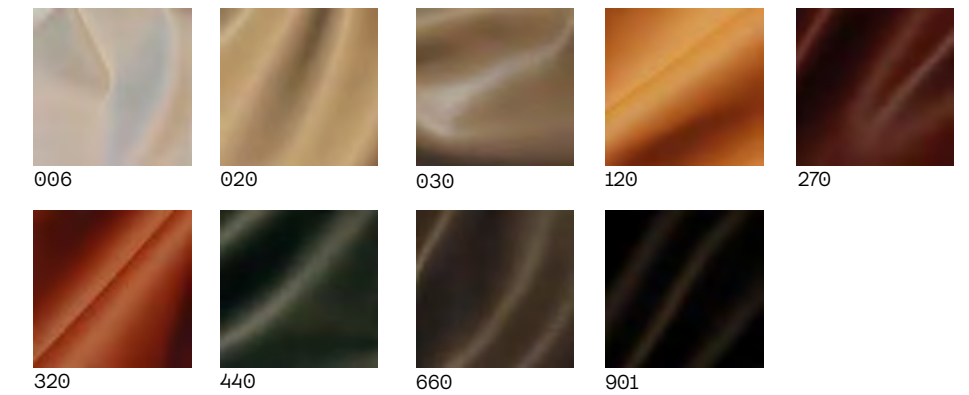

Category B

Best FR

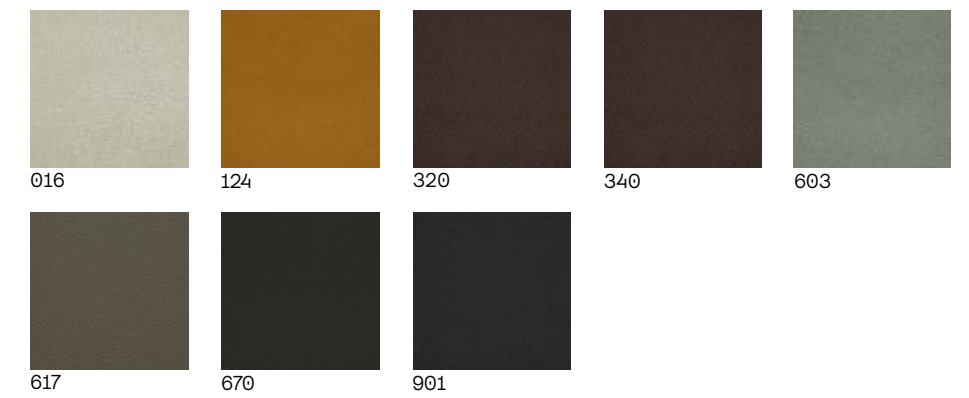

Category C

Vita



Upholstery / Genuine Leather

Category L1

Antik



Category L1

Relax

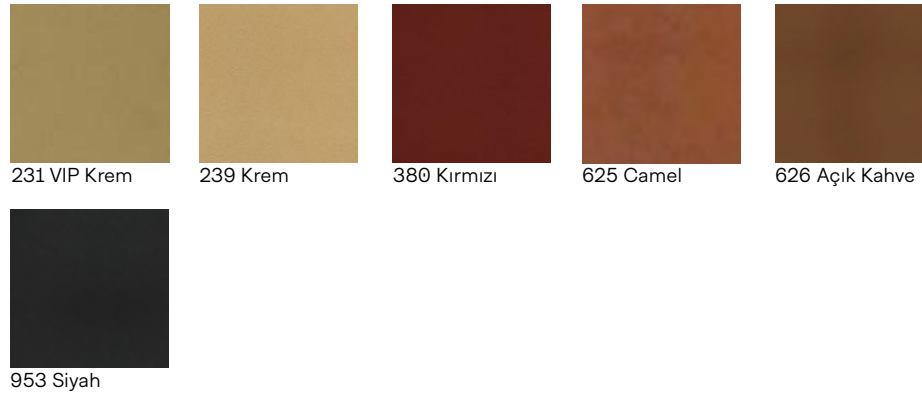

Category L2

Lena

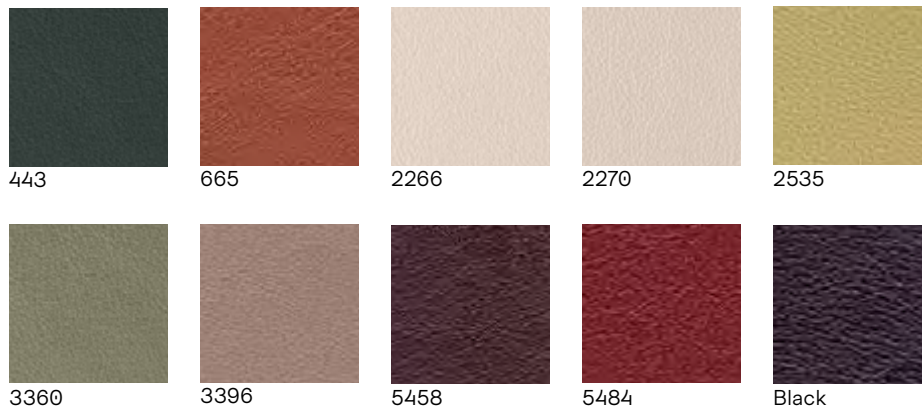

Category L2

Etna

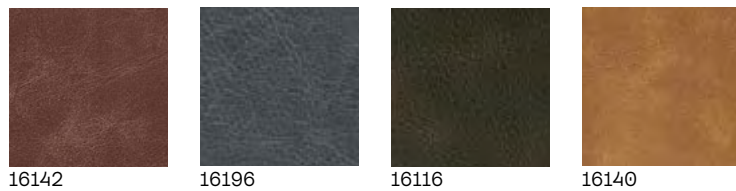

Category L2

Fantasy

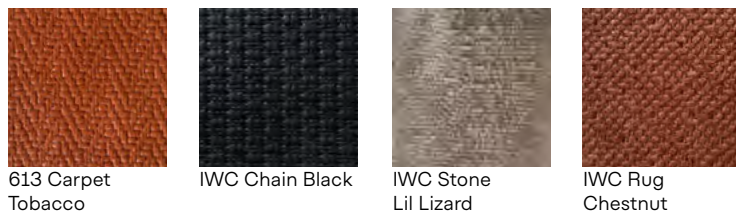

Category L2

Anatolia



Guide for Care & Maintenance

Thank you for choosing Parla.

Our mission is to manufacture products that meet the highest standards in design, quality and functionality.

Regular professional care extends the life time of each product and thus also your satisfaction with its use. You can find some useful information on how to use and carefully maintain our products below.

SOLID WOOD INDOOR USE

The Solid wood we use is an actual living part of the tree it comes from, and is composed of wood fibers that are held together with adhesives.

At Parla, our most popular choice of solid wood is Beech, and what we do is create pieces of lumber that have their own characteristics; unique in grain pattern, colour, and texture. As a result each piece of solid wood displays different behaviour and form when different carving techniques are used. Unlike wood veneer, solid wood pieces are frequently used for curved and multi-dimensional pieces.

ASH

With a neutral colorbase, ash trees are very durable and robust. Ash also has better resistance to sunlight and its possible corruptive effects.

BEECH

Having a light-pink undertone, beech wood is very easy to form, therefore easy to use for curved shapes and round corners requiring further surface processing. Parla Collection products are generally produced using Beech wood.

RECOMMENDATIONS

We recommend cleaning the surface regularly with a slightly damp soft cloth. Do not use heavy chemicals for cleaning purposes and protect the surface from sharp objects to avoid scratching.

*As wood is a living material, variations in colour, pattern, and pigmentation will occur on each piece.

*Wooden furniture will also change appearance over time as it is affected by

the environment (daylight, humidity, etc.) in which it is placed.

*Solid wood furniture should not be placed too close to heat sources nor should it be in frequent contact with liquids.

*Do not use abrasive materials.

WOOD VENEER INDOOR USE

A veneer refers to a thin layer of wood peeled or cut from a section of a tree. It is then bonded onto a thick piece of wood, typically MDF, chipboard, or plywood. These layers are classified later according to their cutting technique and final patterns. At Parla, we use quarter cut veneer sheets with slip matching on plywood as standard. Each veneer table layer is unique. No matter how expertly cut or treated, none of its layers are identical to another, which is the charm of using natural materials. Veneer provides high-quality looks without the need for large amounts of wood consumption.

OAK

A somewhat brittle material when processed, oak is very resistant to heavy weather conditions and harsh climates as a tree. Being a durable and robust form, oak pieces require expertise and unique production techniques.

WALNUT

A tree familiar with mild climates, the walnut tree has high fibers resulting in splendid and rich patterns on its layers. Easy to process, walnut has high aesthetic qualities however it requires suitable methods to bring out its beauty and strength.

RECOMMENDATIONS

We recommend cleaning the surface

regularly with a slightly damp soft cloth. Please wipe the veneer following the direction of the wood grain. Compared to solid wood, wood veneer is less resistant to heat and moisture, especially around the edges where layers of wood are visibly pressed. Extreme heat and any contact to water must be avoided, especially around the edges.

*Veneers generally have color differences compared to their matching solid wood stain options. Which are usually used for chair legs or supportive elements. We, therefore, especially recommend using wood veneer material for stained table tops and legs.

*Do not use oil or ammonia-based products to clean wood veneer.

*Do not use abrasive materials.

METAL INDOOR USE

Metal, brass, aluminium, and stainless steel are the most preferred materials at Parla for the metal components of furniture we produce. Depending on the product type and place of use, metal surfaces are available in Powder Coated Textured (outdoor) or Matte (indoor) or PVD Coated; Polished or Brushed (indoor) finishes.

STAINLESS STEEL

Durable and more accessible, stainless steel is perfect for structural elements and metallic finishes. PVD coating can be used with different finishes, as shown in our coloured steel options.

METAL & ALUMINIUM

Parla recommends Powder Coated metal in matte finish for indoor use and aluminium or treated metal in textured finish for outdoor use. Aluminium is a rust-resistant and light material that can be used directly with powder coating without further treatments. However, we recommend using powder coated aluminium with a textured finish to increase the hold of coatings that protect the metal from heavy conditions of outdoor use.

Metal materials on the other hand need to be pre-coated with cataphoresis treatment before coating for protection over rust and corrosion.

RECOMMENDATIONS

We recommend cleaning the surface with a damp cloth and wiping the surface immediately after.

*Do not use alcohol.

*Avoid using abrasive materials that can alter or scratch the surface.

*For PVD coatings, Parla uses an environmentally friendly Anti Fingerprint solution. Creating a protective layer over stainless steel, this solution creates an easy-to-clean surface, reducing fingerprints.

*It is not recommended to use PVD Coated steel under direct sunlight for extended periods since it can affect the coating colour over time.

GLASS & STONE

GLASS

Characteristic results of glass manufacturing such as tiny air bubbles, thickness variations and light pitting, should always be expected with glass. All glass used in our furniture is tempered to ensure excellent durability. For painted glass, all RAL colour options are available and the final finish is tempered extra clear glass with colour.

MARBLE & STONE

Travertine Stone and marble are natural and porous materials of sedimentary origin. They are usually collected as stone blocks which are later cut into layers of

stone using a delicate process. The texture of these stones depends on grains. The formed and pressured element groups to create mesmerising grains and layers makes each piece unique. The density of these element groups determines the colour and patterns of the stone.

Before using them as furniture parts stones are treated with an invisible solvent-based chemical to sustain their surface integrity. It penetrates stone pores and protects their surface against dirt, dust, water or stains, generating an easy clean effect. Due to its porous nature this treatment must be applied every few months to help the surface reach its entire service life.

RECOMMENDATIONS

We recommend carefully cleaning the surface with a barely damp soft cloth to avoid scratching the surface.

Marble is porous and has a poor resistance to acidic substances (vinegar, lemon juice, wine, tea, coffee, etc.) that even in small quantities can corrode the surface and penetrate into the pores forming spots.

*Do not use any products containing acetone ammonia, chlorine, solvents, abrasive products and furniture polish, since these might permanently damage the surface of the product making it look opaque with marks.

Glass is not scratch-resistant so avoid dragging objects across the surface. Glass is very resistant to heat sources. Still we recommend never placing hot objects directly on the surface since high temperature differences create fragile spots on the surface which, could result in cracks.

*Glass surfaces should be wiped with a clean dry cloth. Cleaning can be done with household ammonia or unique glass cleaning products if the occasion requires it.

*Never use abrasives or sharp -edged tools to prevent scratching.

OUTDOOR

Outdoor furniture needs resistance to heavy weather conditions and direct sunlight. Our experience over time recommends specific types of materials for outdoor furniture, such as Iroko wood, woven ropes, and powder coated textured metal structures.

SOLID WOOD

OUTDOOR USE - IROKO

Iroko is a particular type of timber that grows in rainforest weather conditions, making it highly durable for outdoor use. With its high density of fibers, Iroko can extract minerals and particles from the soil. Because of these features, Iroko grows much faster than traditional timber types and can be produced in a fast-paced sustainable cycle.

Iroko also showcases its stain colors distinctively due to its unique, light yellow based color.

METAL & ALUMINIUM

OUTDOOR USE

Since it is rust-proof, we use powder coated aluminium or pre-treated and powder coated metal structures for outdoor furniture.

For outdoor use, we recommend powder coated metals with a textured finish, pre-coated with cataphoresis treatment to increase the paint's grip and protect the metal from heavy conditions of outdoor use.

For aluminium, powder coating can be applied directly.

ROPES

The weaving technique and rope options create a vast playground for furniture designers. With round and flat options, hand woven ropes are carefully placed according to templates by professionals constructed by very skilled craftsmen. Woven from pre-UV treated strands, outdoor ropes also have a multi-layered internal structure, making them highly resistant to tension, colour fade and heavy weather conditions.

RECOMMENDATIONS

We recommend cleaning the Iroko surface regularly with a slightly damp soft cloth.

*Do not use heavy chemicals for cleaning purposes and protect the surface from sharp objects to avoid scratching.

*Although they can be in touch with it, outdoor furniture mustn't be in direct contact with salt water for long periods of time since it can cause corrosion. Also, direct exposure to sunlight for extended periods will eventually affect Iroko's colour.

*Do not use any chemicals for cleaning powder coated metal, clean with damp cloths or water.

*For extreme weather conditions, UV treatment types for outdoor ropes may vary. Please specify area of use to select the suitable treatment type.

UPHOLSTERY

GENUINE LEATHER

Natural leather has a pleasant characteristic smell and is wear resistant. Its quality depends on the animal's lifestyle as well as on the method of leather processing. Minor defects originating during the animal's life, such as wrinkles, blood veins, scars, scratches, etc. are regarded as permissible and are even required as evidence of the 'genuine and unique' quality of the leather.

RECOMMENDATIONS

The best maintenance for leather is regular vacuuming with a soft brush. Avoid using cleaning products and sharp objects. If cleaning is necessary use boiled water with natural soap shavings of good quality. Whip 2-3 tablespoons of soap flakes in 1-liter water and only use the foam. Apply the foam with a soft cloth, let the furniture dry and dry afterward the leather off thoroughly with a soft cotton cloth.

ARTIFICIAL LEATHER

Artificial leather is usually undemanding in maintenance.

RECOMMENDATIONS

Remove dust regularly with a fine suction force of your vacuum cleaner or with a wet cotton cloth.

*Dry spilled liquids immediately by a dry cotton or paper towel.

*Do not let other stains dry on the surface but remove them immediately with lukewarm water.

*Wipe the surface carefully with a moistened cotton cloth and dry with a dry towel.

FABRIC

Cleaning and maintaining upholstered furniture regularly is important to retain the appearance of the fabric and to prolong its lifespan. Over time, dust and dirt can cause furnishing fabrics to change color and exacerbate wear.

RECOMMENDATIONS

Vacuum the furniture regularly using the upholstery nozzle to remove dust and avoid fluff and pilling. Straighten the fabric with your hands from time to time. Wrinkles in the fabric can be straightened using a steamer. Soak up spilled liquids immediately with an absorbent napkin or cloth by dabbing gently towards the centre of the stain.

*Never use concentrated detergents or bleach, ammonia, optical brighteners or soap intended for hard surfaces.

*We do not recommend spot cleaning of individual marks and stains as this damages the fabric and causes colour loss.

*Avoid rubbing the material hard as this could result in loss of colour and damage the fabric.

We kindly ask you to follow instructions and recommendations contained in this manual.

Regular professional care extends the life of your product and besides can be also a condition for warranty compensations. The manufacturer does not take any responsibility for potential damage to the product resulting from unauthorised use and unprofessional handling of the furniture.

Parla is constantly working on further development of all products, which may cause some changes in used materials, constructions and finishing.

As a result of this the recommendations and guidelines for the proper use of products may be also changed. Thank you for your understanding and we wish you pleasant moments spent while using our products.

**The products displayed in this catalogue are to be considered as sample configurations. The textures, colors of materials, and finishes are indicative due to variations that may result from the printing process.*

For any technical specifications and/or dimensions, please get in contact with our sales team. Parla Design reserves the right to change, without prior notice, materials, covers, finishes, and drawings presented in this catalogue.

parladesign.com



Istanbul Office / Showroom

Bareli İş Merkezi, Ayazmadere Cad.
Pazar Sok. No: 2-4
Beşiktaş 34349 - Istanbul, TURKEY
P +90 (212) 216 61 63 / 64

Istanbul Factory

Boğazköy Atatürk Mah.
Yıldırım Beyazıt Cad. No: 194
Arnavutköy 34285 - Istanbul, TURKEY
P +90 (212) 685 01 42
info@parladesign.com

London Office

4/4A Bloomsbury Square,
WC1A2RP - London, UK
P +44 (0) 20 3865 7703
london@parladesign.com

Dubai Office

Office No: 1509, Sobha Sapphire Bldg
P.O Box: 123377
Business Bay - Dubai, UAE
P +971 4 553 07 28
dubai@parladesign.com

US Office

3445 Rankin Street #3445
Dallas, TX 75205 - USA
P +1 214 577 6070
usa@parladesign.com

parladesign.com

THE IMPRINT

Creative Agency: Muhabbet
Art Direction: Gözde Ulusoy
Photography: Engin Yıldız, Burak
Teoman, Tahir Akkurt

©2023 Parla

*All rights reserved. No part of this
publication may be reproduced, stored
in a retrieval system or transmitted in
any form or by any means, electronical,
mechanical, photocopying, recording or
otherwise; without the prior permission
of the copyright owner.*



Ask for our FSC®-certified products



New York / London / Istanbul / Dubai

www.parladesign.com